



Q3 FY2024 RESULTS

ANALYST & INVESTOR WEB CONFERENCE
JULY 29, 2024

Stabilus SE (the “Company”, later “Stabilus”) has prepared this presentation solely for your information. It should not be treated as giving investment advice. Neither the Company, nor any of its directors, officers, employees, direct or indirect shareholders and advisors nor any other person shall have any liability whatsoever for any direct or indirect losses arising from any use of this presentation.

While the Company has taken all reasonable care to ensure that the facts stated in this presentation are accurate and that the opinions contained in it are fair and reasonable, this presentation is selective in nature. Any opinions expressed in this presentation are subject to change without notice and neither the Company nor any other person is under any obligation to update or keep current the information contained in this presentation. Where this presentation quotes any information or statistics from any external source, you should not interpret that the Company has adopted or endorsed such information or statistics as being accurate. This presentation contains forward-looking statements, which involve risks, uncertainties and assumptions that could cause actual results, performance or events to differ materially from those described in, or expressed or implied by, such statements. These statements reflect the Company’s current knowledge and its expectations and projections about future events and may be identified by the context of such statements or words such as “anticipate,” “believe”, “estimate”, “expect”, “intend”, “plan”, “project” and “target”. No obligation is assumed to update any such statement.

Numbers were rounded to one decimal. Due to rounding, numbers presented may not add up precisely to the totals provided.

Q3: EXPECTED REDUCED CALL-OFFS MATERIALIZED & FIRST-TIME CONSOLIDATION OF DESTACO

STABILUS



Current market environment: **Decline in call-offs from several OEMs** in Q3 FY24 materialized as forecasted, particularly in the electric car segment.

Current **customer demand confirms stabilized volume** developments in Q4 FY24.

Organic revenue growth in APAC¹ (+3.2% y/y) while organic development in EMEA (-5.1% y/y) and Americas (-3.0% y/y) is impacted by lower call-off quantities in the Automotive and Commercial Vehicle markets.

Revenue increase in Q3 FY24, +14.4% y/y, due to the **first-time consolidation of DESTACO results.**

In Q3 FY24, DESTACO generated €48.8m revenue with 19.9% EBIT margin.

DESTACO integration on track. Refinancing of the bridge facility in preparation. Solid project pipeline for advanced indexing conveyors.

¹ See list of acronyms in appendix.

CHALLENGING MARKET ENVIRONMENT IN H2 FY2024

COST FLEXIBILIZATION IN PLACE TO COUNTERBALANCE

STABILUS



We confirm our STAR
2030 goals – in spite of
challenging environment.

Substantial volume reductions in H2 FY2024 are impacting fixed cost coverage and are driving lower profitability which was reflected in the guidance adjustment released on June 11, 2024.

Fixed cost flexibilization actions in all plants and functions in place to counterbalance these challenges.

We will overcome current headwinds, which are to a large extent caused by negative external factors, in the next quarters.

The market environment led to **significant extraordinary expenses** in and continues to do until today. Inflation was severe. Material and energy costs increased dramatically.

Combined, these external factors impacted our profitability significantly and could only be partially recovered from our customers. These effects are by far the major reasons for the reduction in profitability in the years between FY2022 and FY2024.

OUR COUNTERMEASURES MITIGATING NEGATIVE EXTERNAL FACTORS

STABILUS



We will overcome the external headwinds in the coming quarters.

Countermeasures in place:

- **Flexibilization of production** in all impacted plants
- **Efficiency programs** in all plants and functions
- **Continued automation** to counterbalance labor cost inflation
- Continue to drive **inflation recovery measures with suppliers and customers**

We will offset the higher labor cost inflation with **productivity gains and continued automation** and raw material cost inflation through compensation from our customers in the next quarters. **Cost flexibilization and efficiency programs** as well as negotiations with customers and suppliers are ongoing.

DESTACO PERFORMANCE

FIRST QUARTER AS A MEMBER OF THE STABILUS GROUP



INDUSTRIAL AUTOMATON (DESTACO) (€M)

	Q3 FY2024 Actual
Revenue	48.8
EBIT	9.7
<i>% revenue</i>	19.9%
FCF	7.6
<i>% revenue</i>	15.6%



Initial consolidation accomplished;
processes harmonized

First **cross-sale orders** received; ongoing execution of cross-sales initiatives (incl. joint tradeshows), cross-sales workshop conducted, **first joint customer & distributor visits** conducted

Replacement of several existing **Transition Service Agreements (TSAs)**

Procurement savings workshop held; bundling potential for shared suppliers identified, first **joint supplier negotiations** conducted

Corporate **Code of Conduct** rolled out

Site **migrations to Stabilus IT environment** started; half of DESTACO locations equipped with Stabilus infrastructure hardware

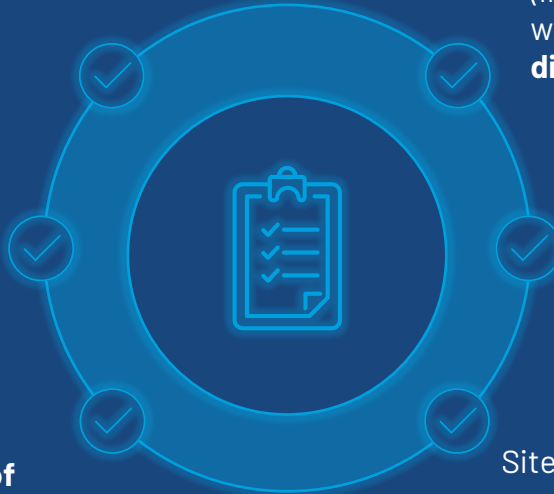

SOLID PROJECT PIPELINE TO STRENGTHEN INDUSTRIAL BUSINESS (PHARMA AND MEDICAL TECHNOLOGY)

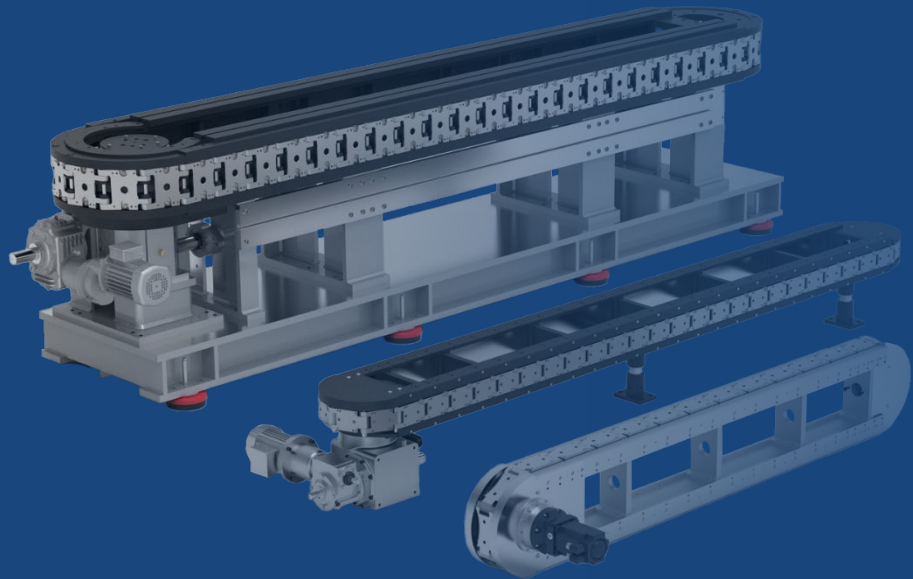

DESTACO continues winning projects for precision link conveyors.



The price of these products amounts to several hundred thousand euros.



Two sets were built for customers in UK / Nordics in the last quarters and shipped in May and June 2024.



End user market segment:
pharma and medical devices



Further promising applications that are in high demand: **consumer goods / personal care** (e.g., the production of safety razors and razor blades), packaging, life sciences, mobility (e.g., batteries) et al.

STABILUS GROUP IN Q3 FY2024

FIRST-TIME INCLUSION OF DESTACO

REVENUE (€M)

□ % organic growth

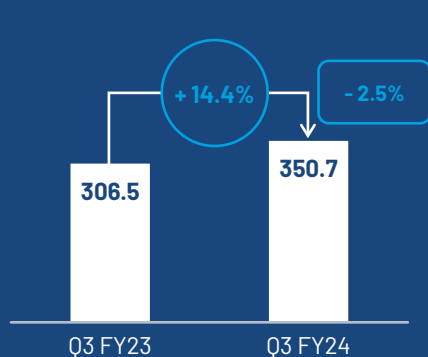

Revenue ▲ 14.4% y/y

- > Organic -2.5%, M&A +17.4%, FX -0.5% y/y
- > M&A effect: Destaco €48.8m, Cultraro €4.6m
- > Growth in APAC¹ offset by less revenues in EMEA and Americas

¹ See list of acronyms in appendix.

ADJ. EBIT (€M)

○ % margin

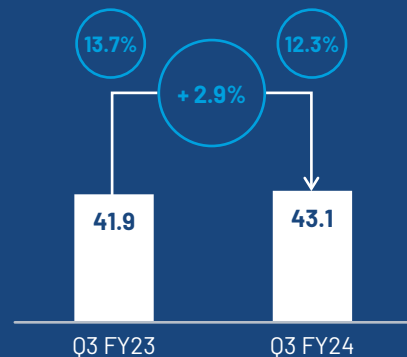

Adj. EBIT margin ▼ 140bp y/y

- > Adj. EBIT +2.9% y/y: Organic -21.5%, M&A +24.6%, FX -0.2%
- > M&A: Destaco €9.7m (19.9% EBIT margin), Cultraro €0.8m
- > Higher profitability of Destaco was partly offset by integration costs (€2m)

PROFIT (€M)

○ % revenue

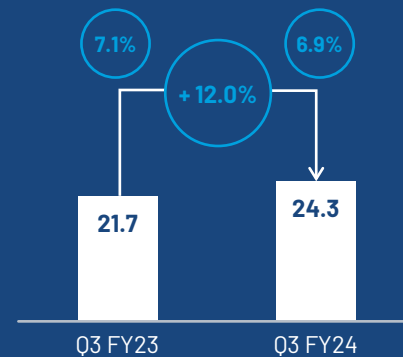

Profit margin ▼ 20bp y/y

- > Higher financing costs in Q3 FY24 due to higher net debt than in prior years

ADJ. FCF (€M)

○ % revenue

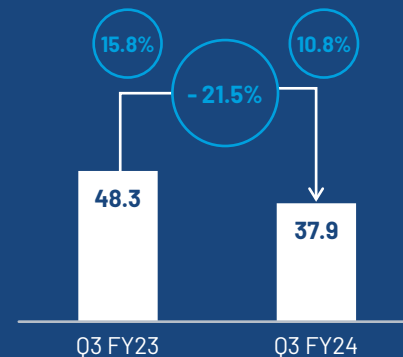

Adj. FCF % revenue ▼ 5.0pp y/y

- > Tax payments in PY €6.2m lower, due to a positive tax ruling and refunds for FY10-FY14; cash inflow from operating activities - €18.2m y/y cash outflow for financing activities + €9.7m y/y
- > Adjustments to FCF €9.0m (PY -)

BUSINESS DEVELOPMENT BY REGION IN Q3 FY2024

STABILUS



AMERICAS



EMEA



ASIA-PACIFIC

Revenue

▲ 21.8% y/y

▲ 8.5% y/y

▲ 13.8% y/y

adj. EBIT margin

11.2%

12.8%

13.2%

▲ 60bp y/y

▼ 190bp y/y

▼ 360bp y/y



Substantial revenue increase due to first-time consolidation of DESTACO.

AMERICAS – MAJOR STEP FORWARD WITH DESTACO; MARGIN IMPACTED BY LABOR COST INFLATION

STABILUS



REVENUE (€M)

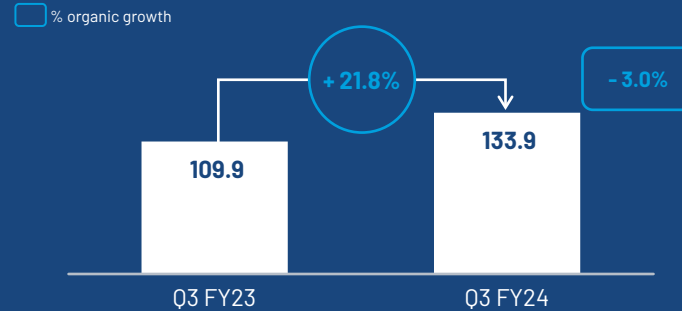

Revenue ▲ 21.8% y/y

- › Organic -3.0%, M&A +24.5%, FX +0.3%
- › M&A: Destaco €26.9m, Cultraro -
- › Less revenues in EC¹, Automotive (esp. APR), AMR and HRF, partly offset by organic growth in DIAMEC and CV

ADJ. EBIT (€M)

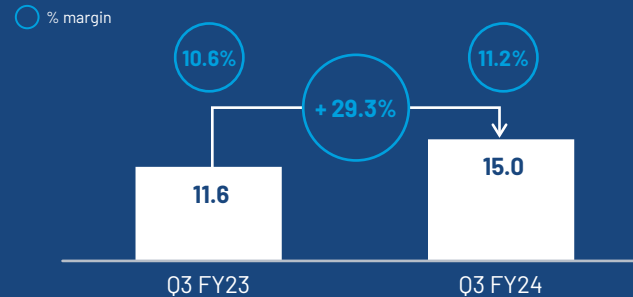

Adj. EBIT margin ▲ 60bp y/y

- › Adj. EBIT +29.3% y/y: Organic -14.6%, M&A +42.2%, FX +1.7% y/y
- › M&A: Destaco €4.9m, Cultraro -
- › Lower fixed cost absorption, continuing high raw material and labor cost inflation

¹ See list of acronyms in appendix.

EMEA – ACQUISITIONS DRIVE REVENUE; WEAKNESS IN AUTOMOTIVE AND COMMERCIAL VEHICLES

STABILUS

REVENUE (€M)

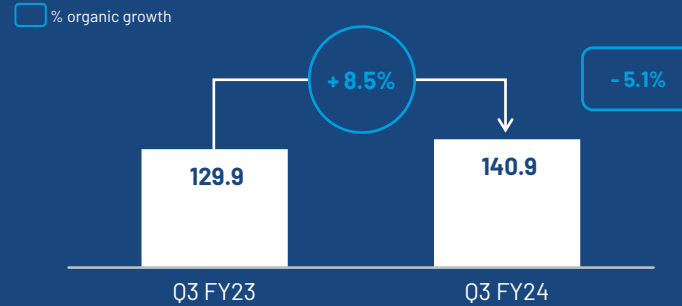

Revenue ▲ 8.5% y/y

- › Organic -5.1%, M&A +14.3%, FX -0.7%
- › M&A: Destaco €14.6m, Cultraro €3.9m
- › Less revenues in Automotive, CV¹ and HRF, partly offset by organic growth in AMR, DIAMEC and EC

ADJ. EBIT (€M)

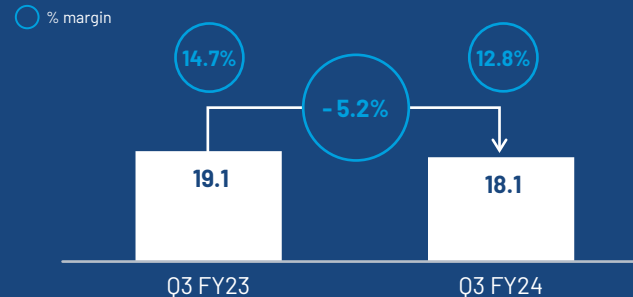

Adj. EBIT margin ▼ 190bp y/y

- › Adj. EBIT -5.2% y/y: Organic -20.9%, M&A +17.3%, FX -1.6% y/y
- › M&A: Destaco €2.7m, Cultraro €0.7m
- › Lower fixed cost absorption, continuing high raw material and labor cost inflation

¹ See list of acronyms in appendix.



REVENUE (€M)

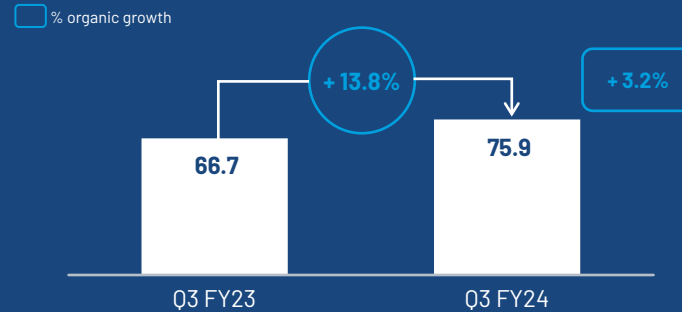

Revenue ▲ 13.8% y/y

- › Organic +3.2%, M&A +12.0%, FX -1.4%
- › M&A: Destaco €7.3m, Cultraro €0.7m
- › Organic growth in Automotive and CV¹, partly offset by less favorable development in DIAMEC

ADJ. EBIT (€M)

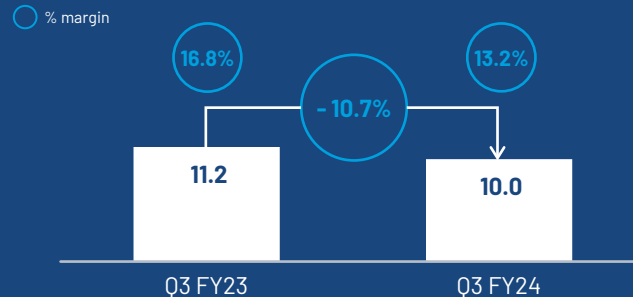

Adj. EBIT margin ▼ 360bp y/y

- › Adj. EBIT -10.7% y/y: Organic -29.5%, M&A +18.8%, FX 0.0% y/y
- › M&A: Destaco €2.1m, Cultraro €0.1m
- › Lower fixed cost absorption, continuing high raw material inflation

¹See list of acronyms in appendix.

BUSINESS DEVELOPMENT BY MARKET SEGMENT

STABILUS

DESTACO CONTRIBUTING TO A BALANCED BUSINESS PORTFOLIO

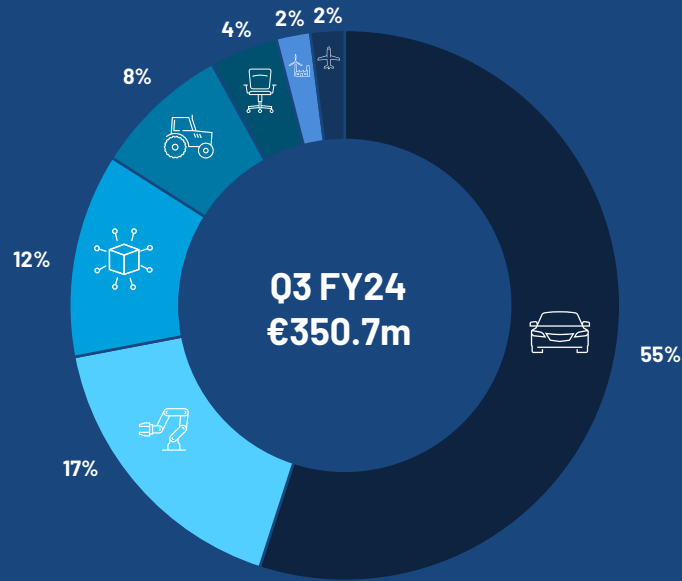

ICON

MARKET SEGMENT

% CHANGE Y/Y



Automotive

▼ 1%



Industrial Machinery & Automation (IMA)

▲ 439%¹



Distributors, Independent Aftermarket, E-commerce (DIAMEC)

▲ 4%



Commercial Vehicles (CV)

▼ 4%



Health, Recreation & Furniture (HRF)

▼ 5%



Energy & Construction (EC)

▼ 26%



Aerospace, Marine & Rail (AMR)

▲ 26%



Strong increase in IMA due to first-time consolidation of DESTACO. Automotive and CV impacted by reduced call-off quantities.

¹ The significant increase is due to the consolidation of DESTACO (€48.8m revenue in Q3 FY24). Change excl. Destaco: -1% y/y.

NET DEBT REDUCED Q/Q - TO €703.2M IN Q3 FY24

FAST DELEVERAGING IS A PRIORITY FOR US



- > Net leverage ratio increased to 2.8 in Q2 FY24, as a consequence of DESTACO acquisition.
- > Our goal is to reduce it well below 2.0 within the next two to three years.
- > Our target leverage ratio is 1.0.
- > Deleveraging started: net debt reduced from €720.2m in Q2 FY24 to €703.2m in Q3 FY24.
- > Our goal remains to stay below a net leverage ratio of 3.0 as of Sept 2024.

SLIGHT INCREASE IN NWC IN Q3 FY24 Q/Q

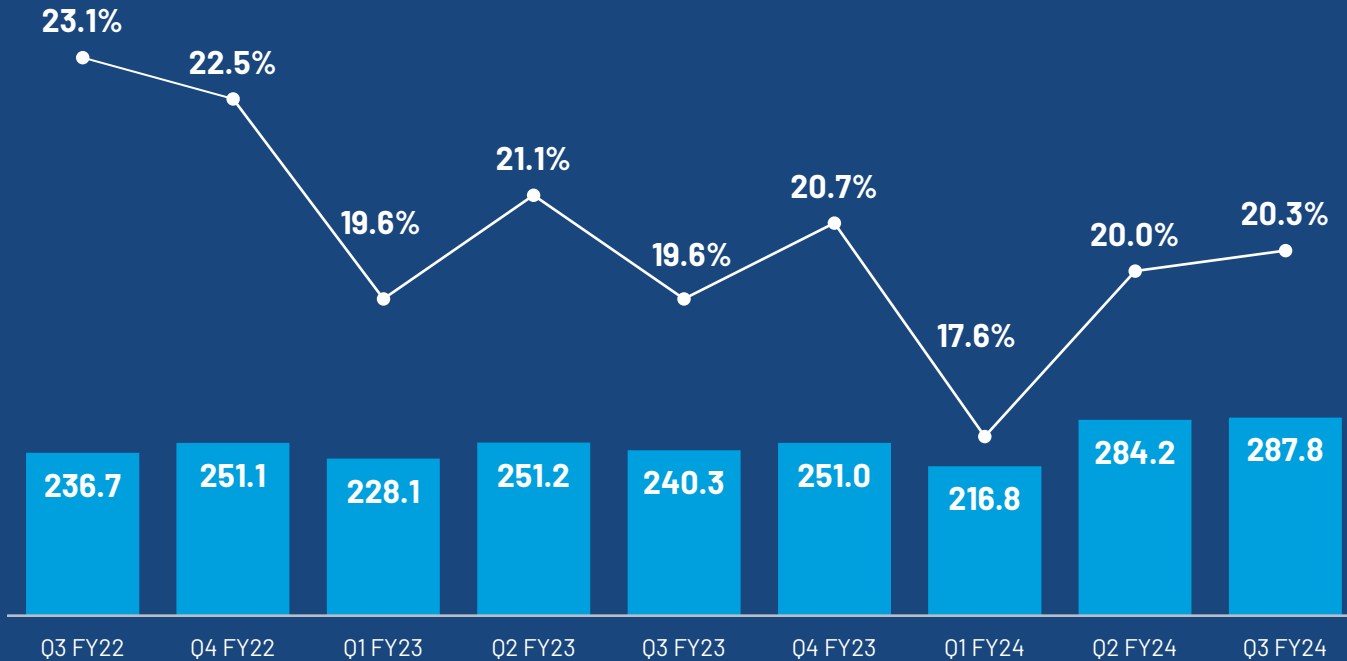

- › NWC/revenue ratio at 20.3%, incl. Destaco's NWC and proforma LTM revenue.
- › The increase from 17.6% in Q1 FY24 to a level above 20% in the following quarters due to the consolidation / inclusion of Destaco and Destaco's comparatively higher NWC/revenue ratio.

CAPEX WILL FACILITATE FUTURE GROWTH WITH INNOVATIVE NEW PRODUCTS SUCH AS DA90

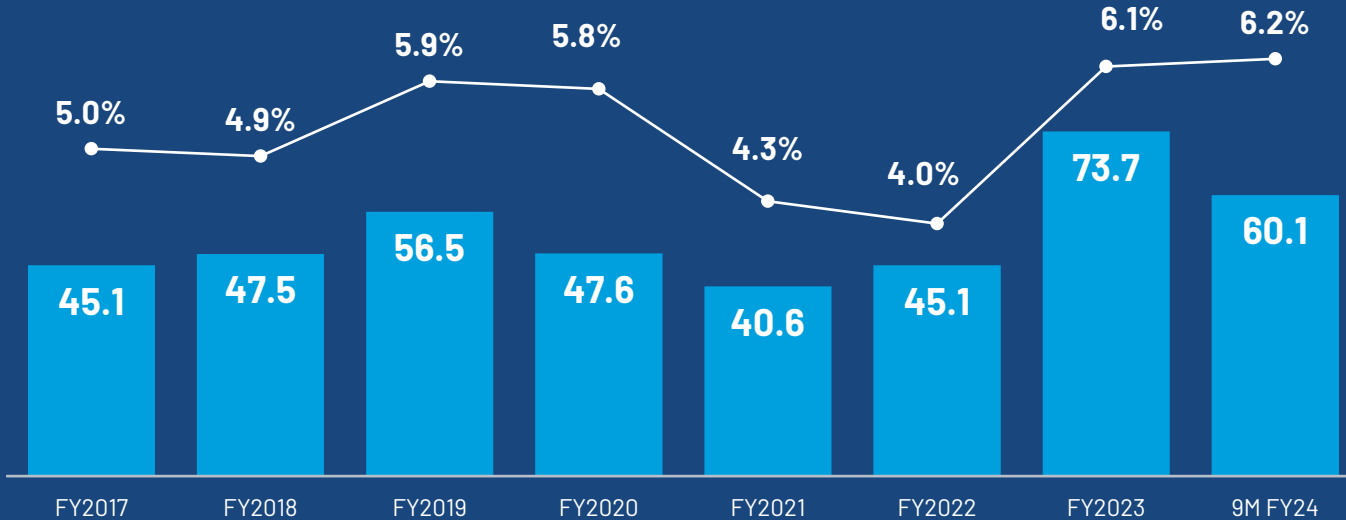

- › In FY2023 and in 9M FY24 capex returned to the usual, historical level of c. 6% of revenue.
- › Investment focus in 9M FY24: radar technology, smart door actuation and automation of production facilities.
- › These investments will facilitate and drive our future revenue growth with innovative new products such as DA90 actuator systems and improve production costs.

	FY2023 Actual	FY2024 Guidance
Revenue	€1,215.3m	€1.3bn – €1.35bn
Adj. EBIT margin	13.0%	11.7% – 12.3%

- › We confirm our FY2024 forecast which was updated on June 11, 2024, considering the revenue of €969.6m with adj. EBIT margin of 11.9% in 9M FY24 and reflecting the current customer demand.
- › The forecast includes DESTACO's results for the six months April – September 2024.



We initiated **measures to increase the robustness and resilience of our businesses**, in particular **cost flexibilization and cost management initiatives** were intensified to mitigate the currently challenging market environment.

We will **offset the higher labor cost inflation with productivity gains and continued automation** and raw material cost inflation through compensation from our customers in the next quarters.

The integration of DESTACO is on track, some workstreams are progressing ahead of plan.

Considering the revenue of €969.6m with adj. EBIT margin of 11.9% in 9M FY24 and reflecting the current customer demand **we are confident to reach the guidance communicated in June 2024.**

We continue to pursue **our long-term strategy STAR 2030**, focusing on profitable and sustainable growth, customer and employee satisfaction, innovation and sustainability.



Q&A SESSION



APPENDIX

REVENUE AND ADJUSTED EBIT MARGIN BY QUARTER

STABILIS

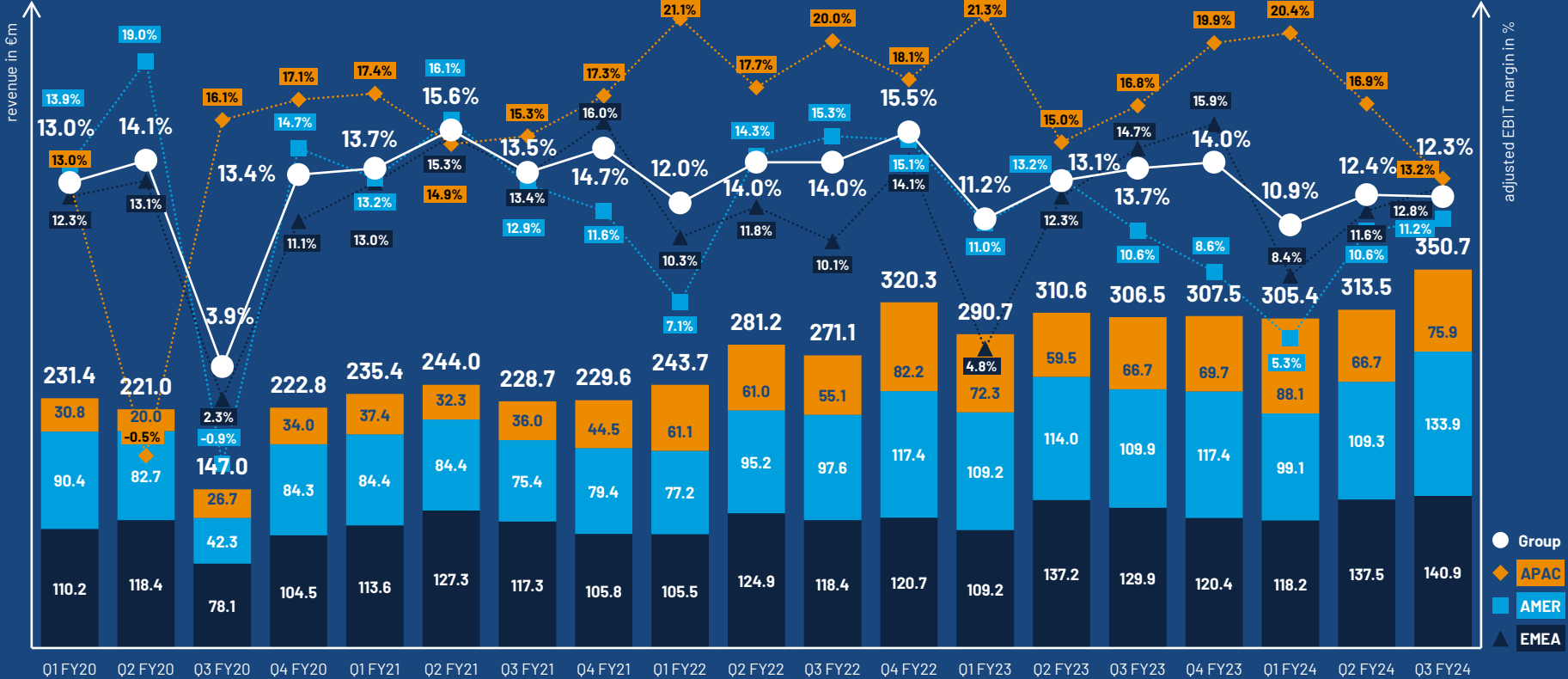

REVENUE

STABILUS

THREE MONTHS ENDED JUNE 30, 2024

REVENUE (€M)

	Q3 FY2023 Actual	Q3 FY2024 Actual	Change	% change	Acquisition effect	Currency effect	Organic growth
Automotive Gas Spring	31.8	32.0	0.2	0.6%	7.4%	0.0%	(6.8)%
Automotive Powerise	30.2	27.7	(2.5)	(8.3)%	0.0%	(0.5)%	(7.8)%
Industrial Components	67.9	66.6	(1.3)	(1.9)%	2.3%	(1.1)%	(3.1)%
Industrial Automation (DESTACO)	-	14.6	14.6	n/a	n/a	n/a	n/a
EMEA	129.9	140.9	11.0	8.5%	14.3%	(0.7)%	(5.1)%
Automotive Gas Spring	30.6	31.1	0.5	1.6%	0.0%	1.9%	(0.3)%
Automotive Powerise	41.2	39.0	(2.2)	(5.3)%	0.0%	3.2%	(8.5)%
Industrial Components	38.1	36.9	(1.2)	(3.1)%	0.0%	(4.0)%	0.9%
Industrial Automation (DESTACO)	-	26.9	26.9	n/a	n/a	n/a	n/a
AMERICAS	109.9	133.9	24.0	21.8%	24.5%	0.3%	(3.0)%
Automotive Gas Spring	24.1	25.7	1.6	6.6%	2.4%	(2.3)%	6.5%
Automotive Powerise	37.1	36.7	(0.4)	(1.1)%	0.0%	(1.5)%	0.4%
Industrial Components	5.5	6.2	0.7	12.7%	2.6%	2.5%	7.6%
Industrial Automation (DESTACO)	-	7.3	7.3	n/a	n/a	n/a	n/a
APAC	66.7	75.9	9.2	13.8%	12.0%	(1.4)%	3.2%
Total Automotive Gas Spring (AGS)	86.5	88.8	2.3	2.7%	3.4%	0.0%	(0.7)%
Total Automotive Powerise (APR)	108.5	103.4	(5.1)	(4.7)%	0.0%	0.6%	(5.3)%
Total Industrial Components (IC)	111.5	109.7	(1.8)	(1.6)%	1.5%	(1.9)%	(1.2)%
Total Industrial Automation (DESTACO)	-	48.8	48.8	n/a	n/a	n/a	n/a
Total	306.5	350.7	44.2	14.4%	17.4%	(0.5)%	(2.5)%

REVENUE

STABILUS

NINE MONTHS ENDED JUNE 30, 2024

REVENUE (€M)

	9M FY2023 Actual	9M FY2024 Actual	Change	% change	Acquisition effect	Currency effect	Organic growth
Automotive Gas Spring	90.3	95.2	4.9	5.4%	7.9%	0.0%	(2.5)%
Automotive Powerise	86.8	86.0	(0.8)	(0.9)%	0.0%	(0.9)%	0.0%
Industrial Components	199.2	200.9	1.7	0.9%	2.2%	(1.6)%	0.3%
Industrial Automation (DESTACO)	-	14.6	14.6	n/a	n/a	n/a	n/a
EMEA	376.2	396.7	20.5	5.4%	7.0%	(1.1)%	(0.5)%
Automotive Gas Spring	89.2	89.4	0.2	0.2%	0.0%	1.4%	(1.2)%
Automotive Powerise	127.1	123.7	(3.4)	(2.7)%	0.0%	5.5%	(8.2)%
Industrial Components	116.7	102.3	(14.4)	(12.3)%	0.0%	(6.6)%	(5.7)%
Industrial Automation (DESTACO)	-	26.9	26.9	n/a	n/a	n/a	n/a
AMERICAS	333.0	342.3	9.3	2.8%	8.1%	0.2%	(5.5)%
Automotive Gas Spring	75.3	81.0	5.7	7.6%	1.8%	(5.5)%	11.3%
Automotive Powerise	106.7	124.4	17.7	16.6%	0.0%	(5.7)%	22.3%
Industrial Components	16.5	18.0	1.5	9.1%	2.1%	(3.9)%	10.9%
Industrial Automation (DESTACO)	-	7.3	7.3	n/a	n/a	n/a	n/a
APAC	198.5	230.6	32.1	16.2%	4.5%	(5.5)%	17.2%
Total Automotive Gas Spring (AGS)	254.8	265.5	10.7	4.2%	3.4%	(1.1)%	1.9%
Total Automotive Powerise (APR)	320.6	334.1	13.5	4.2%	0.0%	0.1%	4.1%
Total Industrial Components (IC)	332.4	321.2	(11.2)	(3.4)%	1.4%	(3.5)%	(1.3)%
Total Industrial Automation (DESTACO)	-	48.8	48.8	n/a	n/a	n/a	n/a
Total	907.8	969.6	61.8	6.8%	6.8%	(1.6)%	1.6%

ADJUSTED EBIT

STABILUS

THREE AND NINE MONTHS ENDED JUNE 30, 2024

ADJUSTED EBIT (€M)

	03 FY2023 Actual	03 FY2024 Actual	Change	% change	Acquisition effect	Currency effect	Organic change
EMEA	19.1	18.1	(1.0)	(5.2)%	17.3%	(1.6)%	(20.9)%
AMERICAS	11.6	15.0	3.4	29.3%	42.2%	1.7%	(14.6)%
APAC	11.2	10.0	(1.2)	(10.7)%	18.8%	0.0%	(29.5)%
Total	41.9	43.1	1.2	2.9%	24.6%	(0.2)%	(21.5)%

	9M FY2023 Actual	9M FY2024 Actual	Change	% change	Acquisition effect	Currency effect	Organic change
EMEA	41.2	44.1	2.9	7.0%	12.6%	(2.2)%	(3.4)%
AMERICAS	38.5	31.8	(6.7)	(17.4)%	12.7%	(4.7)%	(25.4)%
APAC	35.5	39.3	3.8	10.7%	6.5%	(5.1)%	9.3%
Total	115.3	115.2	(0.1)	(0.1)%	10.8%	(3.9)%	(7.0)%

P&L AND ADJUSTED EBIT

STABILUS

THREE MONTHS ENDED JUNE 30, 2024

P&L (€M)

	Q3 FY2023 Actual	Q3 FY2024 Actual	Change	% change
Revenue	306.5	350.7	44.2	14.4%
Cost of sales	(226.2)	(256.3)	(30.1)	13.3%
Gross Profit	80.3	94.4	14.1	17.6%
<i>% margin</i>	26.2%	26.9%		
R&D expenses	(7.8)	(9.1)	(1.3)	16.7%
Selling expenses	(24.1)	(31.4)	(7.3)	30.3%
Administrative expenses	(10.4)	(18.8)	(8.4)	80.8%
Other income/expenses	0.4	4.2	3.8	>100.0%
EBIT	38.4	39.3	0.9	2.3%
<i>% margin</i>	12.5%	11.2%		
Finance income/costs	(5.2)	(6.2)	(1.0)	19.2%
EBT	33.2	33.0	(0.2)	(0.6)%
<i>% margin</i>	10.8%	9.4%		
Income tax	(11.5)	(8.7)	2.8	(24.3)%
Profit	21.7	24.3	2.6	12.0%
<i>% margin</i>	7.1%	6.9%		
EPS in €	0.86	0.97	0.11	12.8%

ADJUSTED EBIT (€M)

	Q3 FY2023 Actual	Q3 FY2024 Actual	Change	% change
EBIT	38.4	39.3	0.9	2.3%
PPA adj. - D&A	3.4	3.9	0.5	14.7%
Advisory costs	-	0.8	0.8	n/a
PPA adjustments	0.1	(0.9)	(1.0)	<(100.0)%
Total adjustments	3.5	3.8	0.3	8.6%
Adjusted EBIT	41.9	43.1	1.2	2.9%
<i>% margin</i>	13.7%	12.3%		

P&L AND ADJUSTED EBIT

STABILUS

NINE MONTHS ENDED JUNE 30, 2024

P&L (€M)

	9M FY2023 Actual	9M FY2024 Actual	Change	% change
Revenue	907.8	969.6	61.8	6.8%
Cost of sales	(666.3)	(717.8)	(51.5)	7.7%
Gross Profit	241.4	251.8	10.4	4.3%
<i>% margin</i>	26.6%	26.0%		
R&D expenses	(26.4)	(26.0)	0.4	(1.5)%
Selling expenses	(77.5)	(85.9)	(8.4)	10.8%
Administrative expenses	(32.4)	(57.6)	(25.2)	77.8%
Other income/expenses	(0.6)	8.2	8.8	<(100.0)%
EBIT	104.6	90.5	(14.1)	(13.5)%
<i>% margin</i>	11.5%	9.3%		
Finance income/costs	(17.6)	(13.2)	4.4	(25.0)%
EBT	87.0	77.3	(9.7)	(11.1)%
<i>% margin</i>	9.6%	8.0%		
Income tax	(7.2)	(22.8)	(15.6)	>100.0%
Profit	79.8	54.5	(25.3)	(31.7)%
<i>% margin</i>	8.8%	5.6%		
EPS in €	3.19	2.15	(1.04)	(32.6)%

ADJUSTED EBIT (€M)

	9M FY2023 Actual	9M FY2024 Actual	Change	% change
EBIT	104.6	90.5	(14.1)	(13.5)%
PPA adj. - D&A	10.5	12.1	1.6	15.2%
Advisory costs	-	13.4	13.4	n/a
PPA adjustments	0.2	(0.8)	(1.0)	<(100.0)%
Total adjustments	10.7	24.7	14.0	>100.0%
Adjusted EBIT	115.3	115.2	(0.1)	(0.1)%
<i>% margin</i>	12.7%	11.9%		

BALANCE SHEET

STABILUS

JUNE 30, 2024

BALANCE SHEET (€M)

	Sept 2023 Actual	June 2024 Actual	Change	% change
Property, plant and equipm.	247.2	284.4	37.2	15.0%
Goodwill	236.6	808.2	571.6	>100.0%
Other intangible assets	230.0	226.6	(3.4)	(1.5)%
Other investments	6.0	6.0	-	0.0%
Inventories	177.3	221.7	44.4	25.0%
Trade receivables	198.0	215.7	17.7	8.9%
Other assets	46.1	69.3	23.2	50.3%
Cash	193.1	139.4	(53.7)	(27.8)%
Total assets	1,334.3	1,971.3	637.0	47.7%
Equity incl. minorities	712.0	704.6	(7.4)	(1.0)%
Debt (incl. accrued interest)	258.0	842.6	584.6	>100.0%
Pension plans	37.7	46.3	8.6	22.8%
Deferred tax liabilities	44.6	43.2	(1.4)	(3.1)%
Trade payables	124.3	149.6	25.3	20.4%
Other liabilities	157.7	185.0	27.3	17.3%
Total equity and liabilities	1,334.3	1,971.3	637.0	47.7%

- › The identification and measurement of the assets and liabilities acquired not yet concluded as of June 30, 2024.
- › The difference between the consideration transferred and the carrying amount of the net assets acquired temporarily and provisionally allocated in full to the goodwill.
- › The PPA started and will modify the preliminary allocation.

CASH FLOW

STABILUS

THREE MONTHS ENDED JUNE 30, 2024

CASH FLOW STATEMENT (€M)

	Q3 FY2023 Actual	Q3 FY2024 Actual	Change	% change
Cash flow from operating activities	70.3	52.1	(18.2)	(25.9)%
Cash flow from investing activities	(22.0)	(23.2)	(1.2)	5.5%
Cash flow from financing activities	(3.4)	(13.1)	(9.7)	>100.0%
Net increase / (decrease) in cash	45.0	15.7	(29.3)	(65.1)%
Effect of movements in exchange rates	(2.1)	(0.8)	1.3	(61.9)%
Cash as of beginning of the period	155.4	124.4	(31.0)	(19.9)%
Cash as of end of the period	198.3	139.4	(58.9)	(29.7)%

ADJ. FCF (€M)

	Q3 FY2023 Actual	Q3 FY2024 Actual	Change	% change
Cash flow from operating activities	70.3	52.1	(18.2)	(25.9)%
Cash flow from investing activities	(22.0)	(23.2)	(1.2)	5.5%
Free cash flow	48.3	28.9	(19.4)	(40.2)%
Adjustments	-	9.0	9.0	n/a
Adj. FCF	48.3	37.9	(10.4)	(21.5)%

CASH FLOW

NINE MONTHS ENDED JUNE 30, 2024

CASH FLOW STATEMENT (€M)

	9M FY2023 Actual	9M FY2024 Actual	Change	% change
Cash flow from operating activities	137.9	122.3	(15.6)	(11.3)%
Cash flow from investing activities	(45.1)	(695.4)	(650.3)	>100.0%
Cash flow from financing activities	(55.2)	521.4	576.6	<(100.0)%
Net increase / (decrease) in cash	37.6	(51.7)	(89.3)	<(100.0)%
Effect of movements in exchange rates	(7.7)	(2.1)	5.6	(72.7)%
Cash as of beginning of the period	168.4	193.1	24.7	14.7%
Cash as of end of the period	198.3	139.4	(58.9)	(29.7)%

ADJ. FCF (€M)

	9M FY2023 Actual	9M FY2024 Actual	Change	% change
Cash flow from operating activities	137.9	122.3	(15.6)	(11.3)%
Cash flow from investing activities	(45.1)	(695.4)	(650.3)	>100.0%
Free cash flow	92.8	(573.1)	(665.9)	<(100.0)%
Adjustments	0.3	650.9	650.6	>100.0%
Adj. FCF	93.1	77.8	(15.3)	(16.4)%

LVP DEVELOPMENT / FORECAST

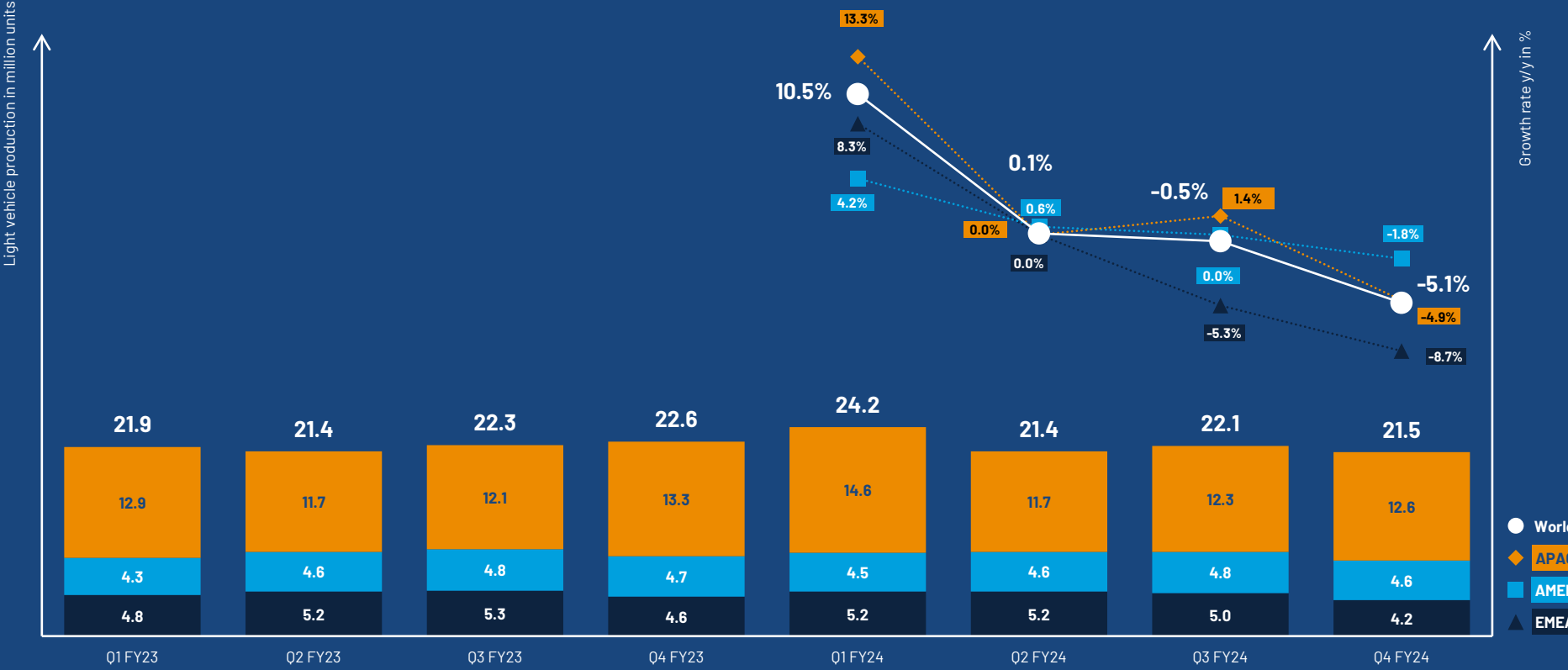

Adj.	Adjusted	FX	Foreign exchange, currency effect
AGS	Automotive Gas Spring	FY	Fiscal year
AMR	Aerospace, Marine & Rail	HRF	Health, Recreation & Furniture
APAC	Asia-Pacific	IMA	Industrial Machinery & Automation
APR	Automotive Powerise	LTM	Last twelve months
bp	Basis point	LVP	Light vehicle production
CAPEX	Capital expenditure	M&A	Mergers & Acquisitions, acquisition effect
CV	Commercial Vehicles	NWC	Net working capital
CY	Calendar year	pp	Percentage point
D&A	Depreciation and amortization	PPA	Purchase price allocation
DIAMEC	Distributors, Independent Aftermarket, E-commerce	PY	Prior year
EMEA	Europe, Middle East & Africa	q/q	Quarter-on-quarter
EBIT	Earnings before interest and taxes	y/y	Year-on-year
EBITDA	Earnings before interest, taxes, depreciation and amortization		
EBT	Earnings before taxes		
EC	Energy & Construction		
FCF	Free cash flow		



STABILUS

M O T I O N C O N T R O L

Experience Stabilus motion control virtually
GROUP.STABILUS.COM/BUSINESS-PARK-MEDIA



Contact Stabilus IR
IR.STABILUS.COM