

# Web Cast Presentation

## Fourth Quarter FY 2010

### London, 23 November 2010

## Infineon Technologies AG

Ulrich Pelzer  
Corp. Vice President  
Corp. Development & IR

Peter Schiefer  
Head of Operations, Division VP  
Industrial & Multimarket



# Table of contents

■ Infineon Results and Outlook

■ Business Highlights

■ Infineon's Superior Manufacturing Technologies

# In Q4 Revenue and Profitability of IFX Improved

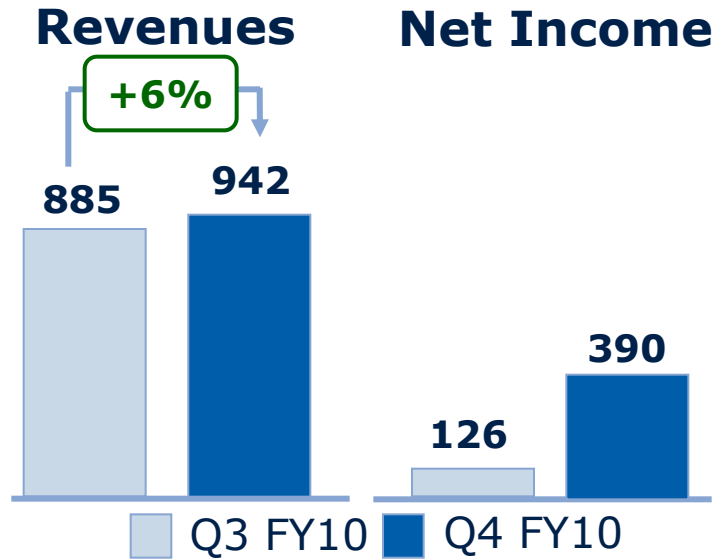

[EUR m]	Q3 FY10	Q4 FY10
Revenues	885	942
Segment Result	138	171
Net Income	126	390
Employees	25,978	26,654
Free Cash Flow	173	236
Gross Cash Position	1,514	1,727
Net Cash	1,108	1,331
Equity Ratio	51%	53%

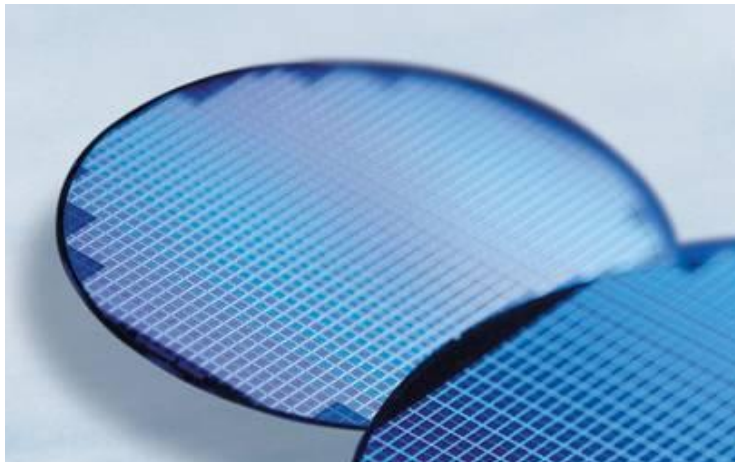

Notes: IFX Continued Operations (excl. WLS) for Revenues and Segment Result and Free Cash Flow; Employees are all current IFX employees without temporary employees; Net Income, Gross Cash, Net Cash and Equity Ratio as reported.

# SR Margin from Cont. Ops Was 18%; Net Income EUR 390m



## Q4 FY10 [EUR m]



### Segment Result

33

Revenue in € million

138

Segment Result margin

171

### Net Income

11

126

390

Note: Revenue and Segment Result Infineon Continued Operations (excl. WLS), Net Income IFX as reported (incl. WLS)

# Higher Investments in Response to Demand and 300mm-Thin-Wafer Pilot Line



## Investments<sup>1)</sup>

## D&A

[EUR m]

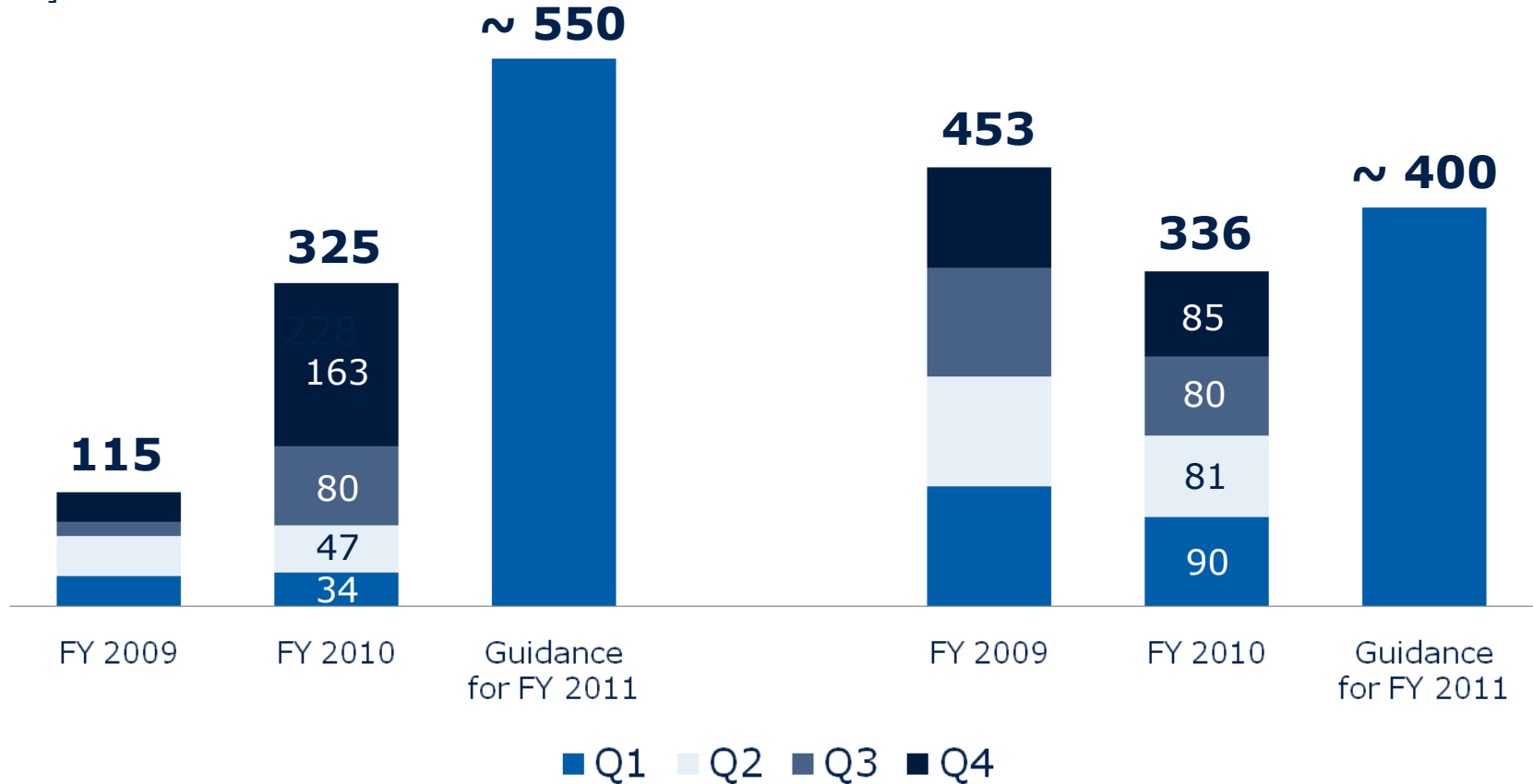

1) For definition please see slide 34 in appendix.

# Net Cash Rose to EUR 1.3bn

## Liquidity Development

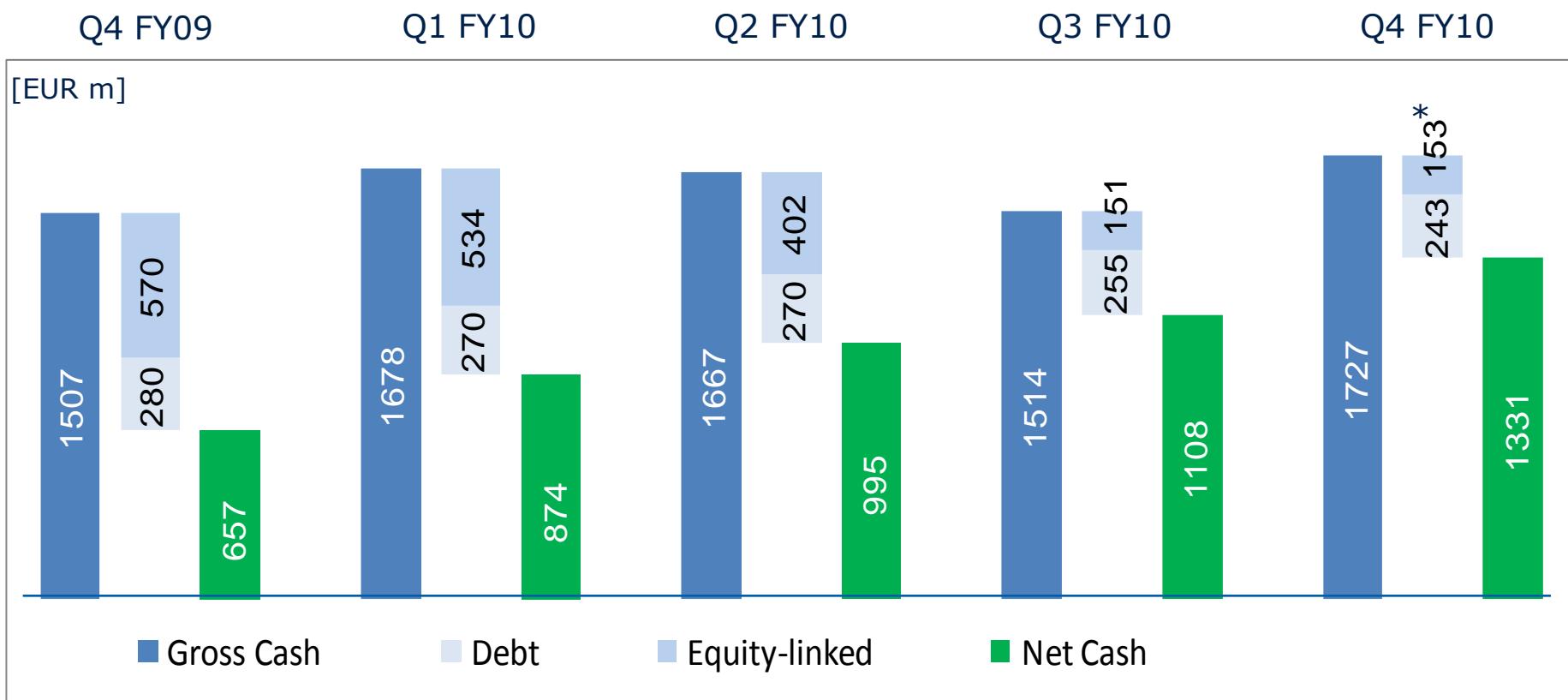

\* Consists of Convertible Bond 2014 (nominal value EUR 196m; book value EUR 153m).

- Strong improvement of net cash position driven by large free cash flow from continuing operations of EUR 236m in Q4 FY10.
- Low leverage including in-the-money convertible 2014.

# WLS Transaction Will Enable a Strategic Cash Position



[EUR bn]

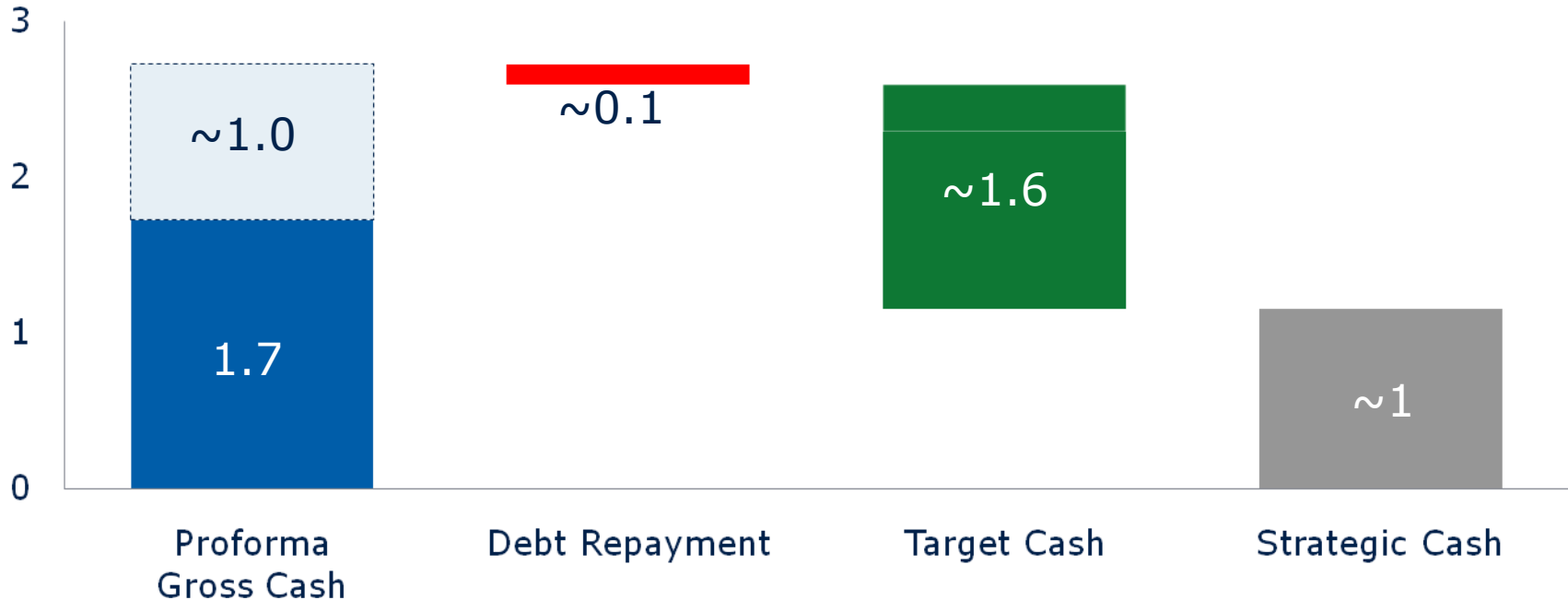

- Proforma gross cash: EUR 1.727bn as per Sep 2010 plus EUR ~1bn proceeds from the sale of WLS.

- Short-term debt scheduled for repayment in FY 2011.

- Target: Gross cash 30–40% of revenue
- Solid liquidity to allow investing through the cycle and sustainable dividend payments.

#### Potential use:

- Funding organic growth (capacity expansion and efficiency improvements) and 300mm thin-wafer development.
- Return of capital to shareholders (share buy-back).
- Acquisitions.

# Another Year of Growth in FY 2011; Continuing Strong Operat. Performance



Outlook Q1 FY11  
(compared to Q4 FY10)

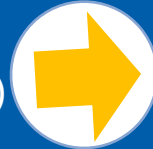

Outlook FY 2011  
(compared to FY 2010)



Infineon  
Revenue

Revenue flat to  
down slightly.

Revenue to  
grow close to 10%.

Combined  
Segment  
Result  
Margin

Margin to remain  
about flat.

Margin to be mid to  
high teens percentage.



# Table of Contents

■ Infineon Results and Outlook

■ **Business Highlights**

■ Infineon's Superior Manufacturing Technologies

# Revenue Split by Division

## 12-months FY 2010 revenue split

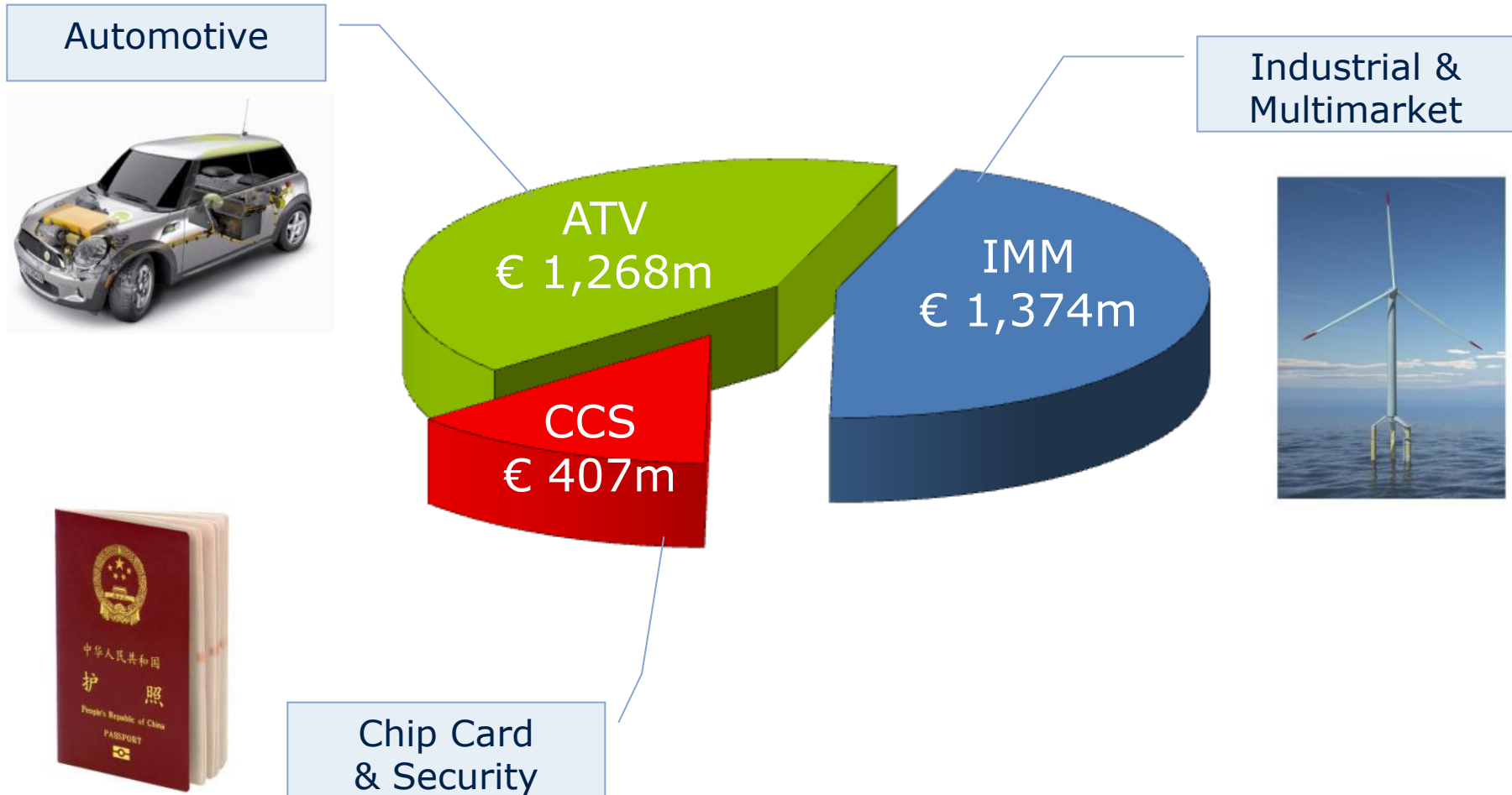

# Infineon Holds #1 Positions in All Target Markets



**Auto-  
motive**

**#1**

Market  
share

9%

Calendar Year 2009  
Source: Strategy Analytics,  
May 2010

**Power**

**#1**

Market  
share

11%

Calendar Year 2009  
Source: IMS Research,  
August 2010

**Chip Card**

**#1**

Market  
share

27%

Calendar Year 2009  
Source: Frost & Sullivan,  
October 2010

# Chip Card & Security Segment (CCS)

## Revenue and Segment Result from Q1 FY08 to Q4 FY10

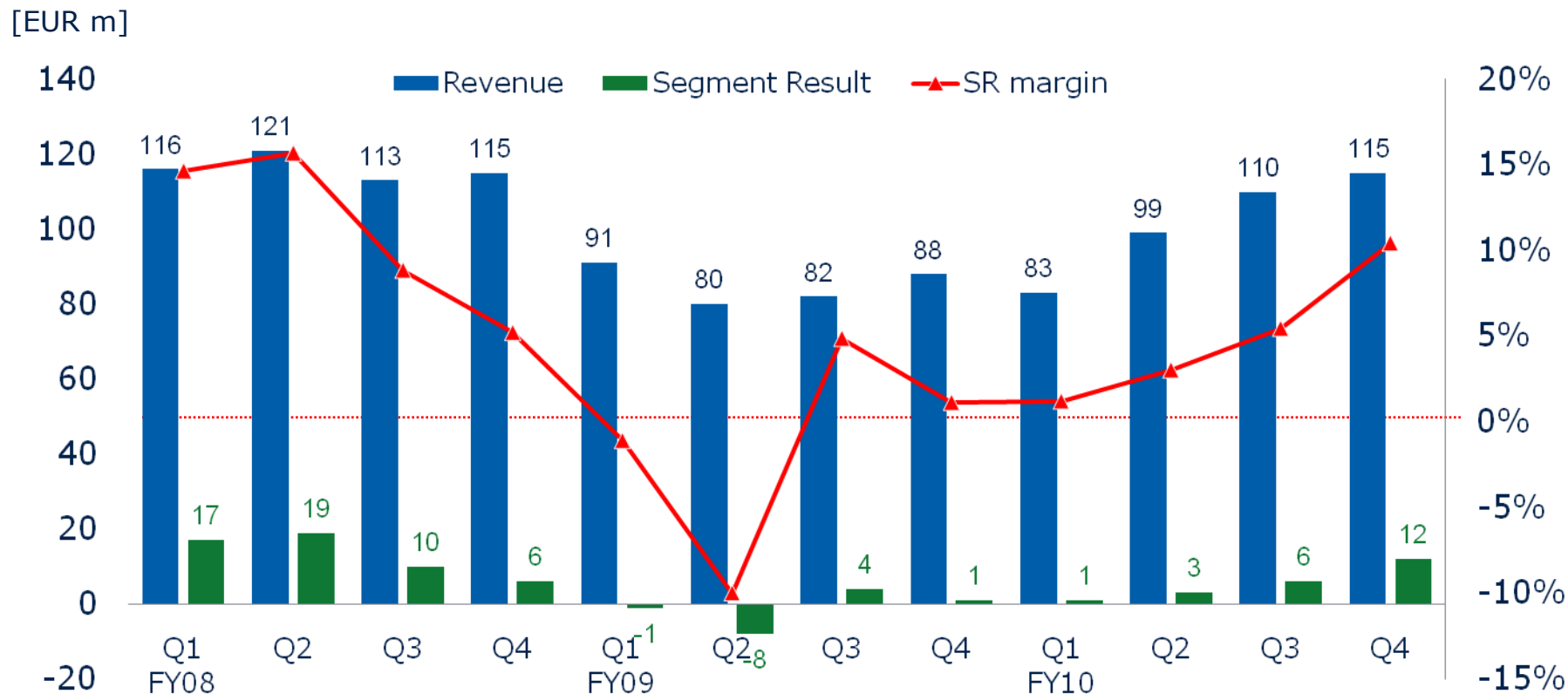

■ Sales in Q4 was driven by higher demand in certain government ID projects. Segment result doubled to EUR 12m compared with Q3.

# Automotive Segment (ATV)

## Revenue and Segment Result from Q1 FY08 to Q4 FY10

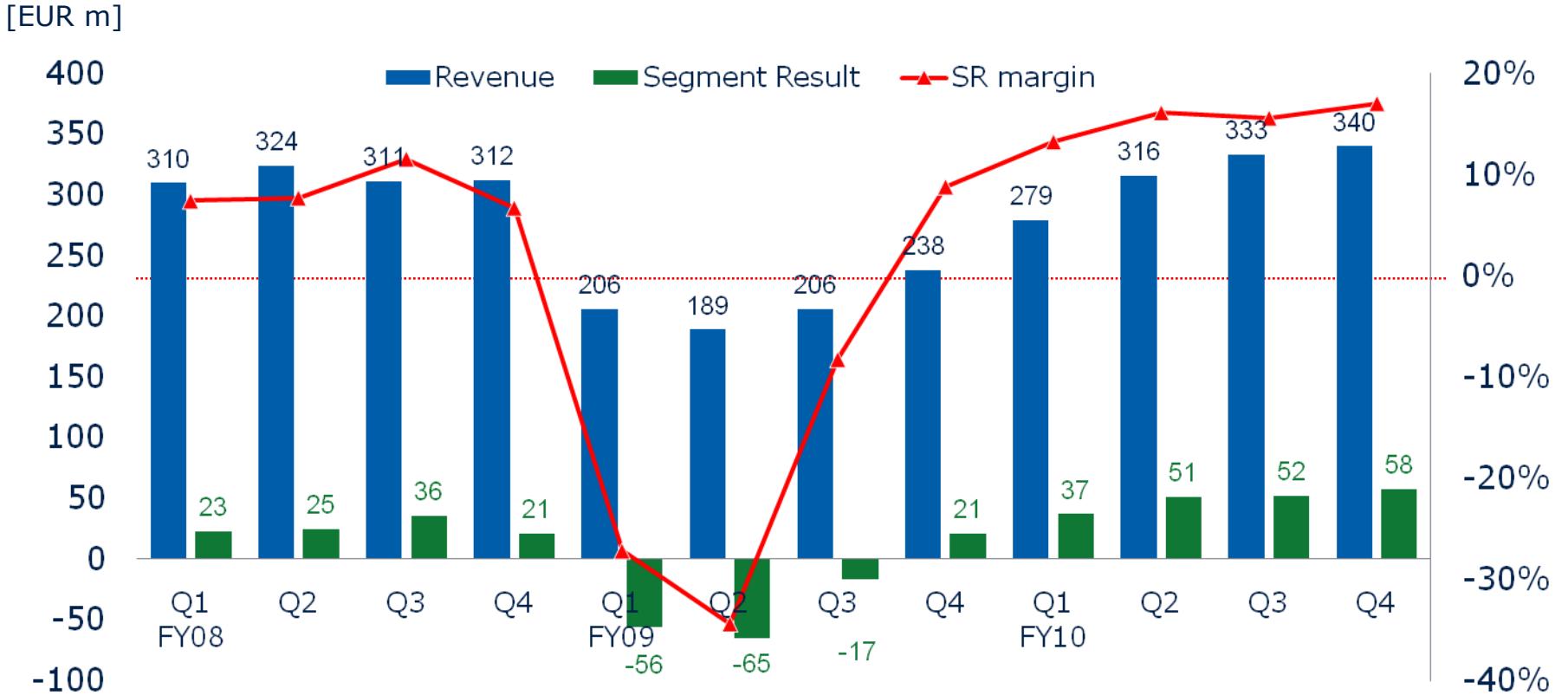

■ Sales in Q4 was driven by continued strong demand in all regions and across the entire product range. Segment result margin again slightly up to 17.1%.

# Four Infineon Sensors in Each and Every Car Worldwide on Average



Courtesy of BMW.



Courtesy of BMW.



Courtesy of Bosch.

## Engine Management



- Hall sensor TLE 4983 for camshaft position detection.

## Transmission



- Differential Hall effect sensor TLE 4953 for 8-gear transmission.

## Safety



- GMR sensor TLE 5012, steering angle sensor for steering column.

# 25m Bicycles Sold in China in 2009; 1 Out of 3 Uses Infineon Semiconductors



## Infineon's solutions and system know-how for e-vehicle applications

### Microcontroller

- High-performance 8- and 16-bit  $\mu$ C

### MOSFETs

- OptiMOS and CoolMOS

### Gate Driver ICs

- 3-phase Bridge Driver ICs

### Power Supply

- Linear and DC/DC Voltage Regulator
- PFC/LLC Controller
- CoolSET
- SiC Diodes

### Communication

- CAN and LIN Transceivers

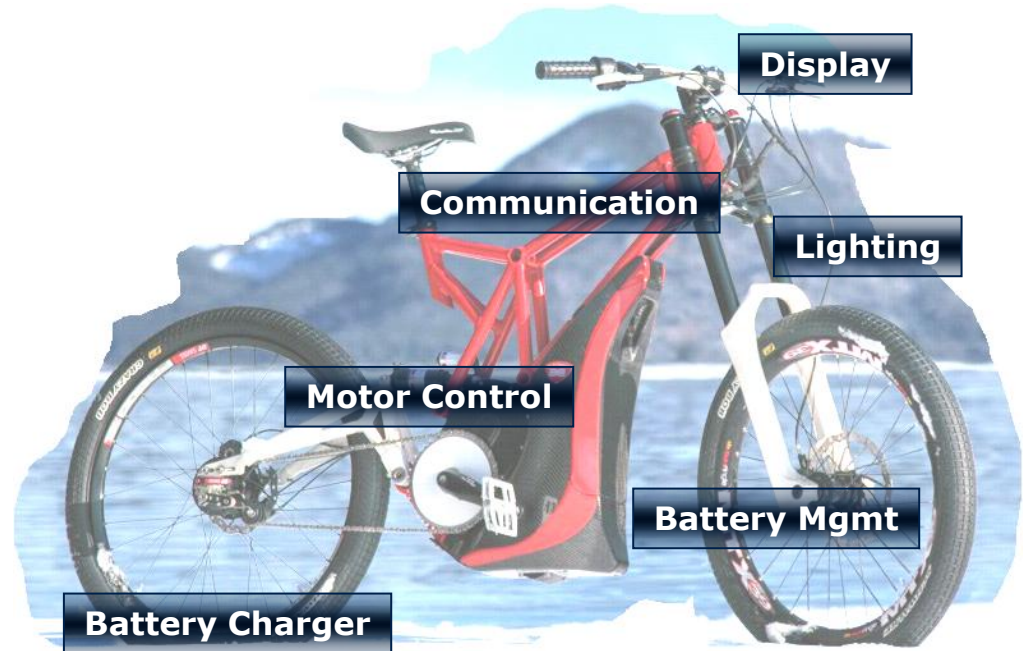

### Sensors

- iGMR Angle Sensors
- Hall Switches
- Current Measurement

### LED Lighting

- Linear LED Driver IC's
- Switched Mode LED Drivers
- Smart Power Switches

# Industrial & Multimarket Segment (IMM)

## Revenue and Segment Result from Q1 FY08 to Q4 FY10

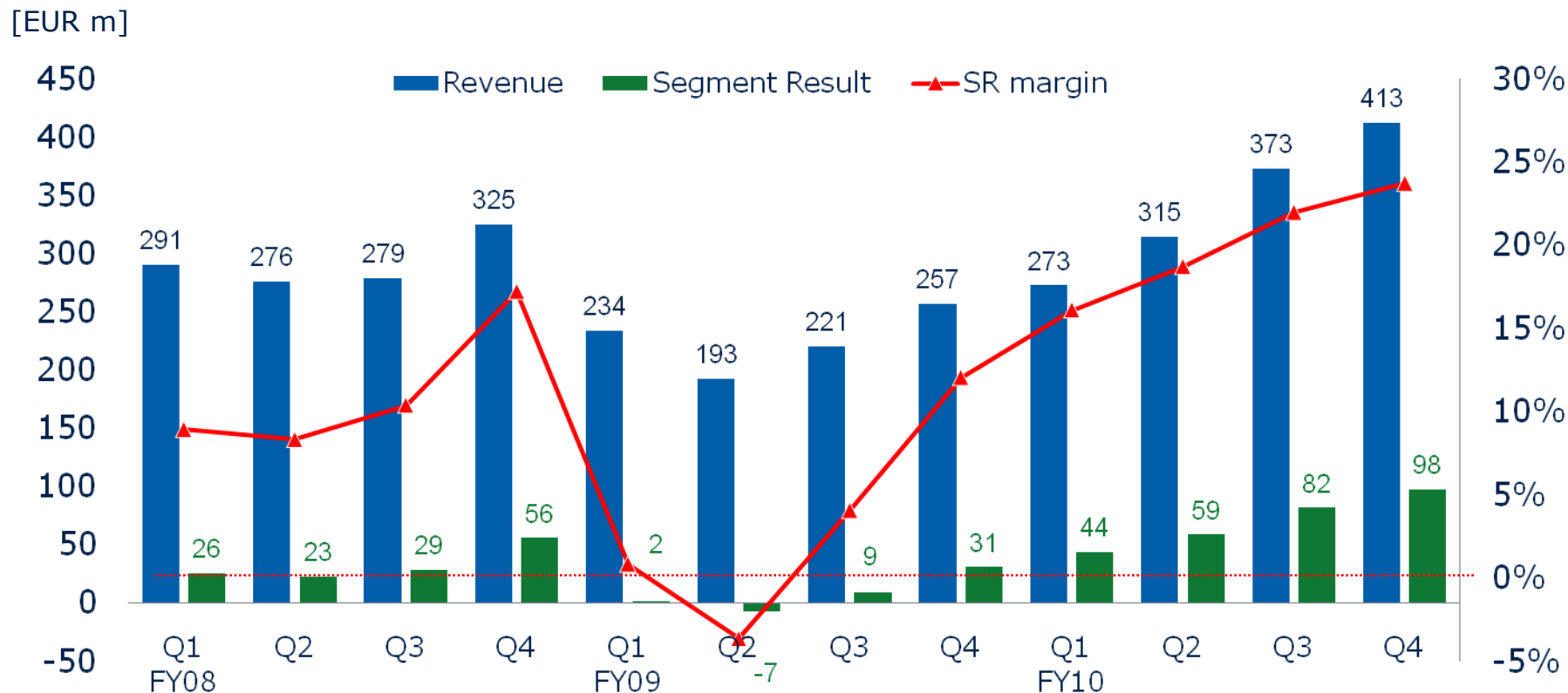

■ Revenue, segment result and segment result margin came in at an all time high in Q4 of EUR 413m, EUR 98m and 23.7%, respectively.



# IMM Achieves Around 3/4 of its Revenues With Power Products; 1/4 With Non-power Products

## IMM revenue split, FY 2010

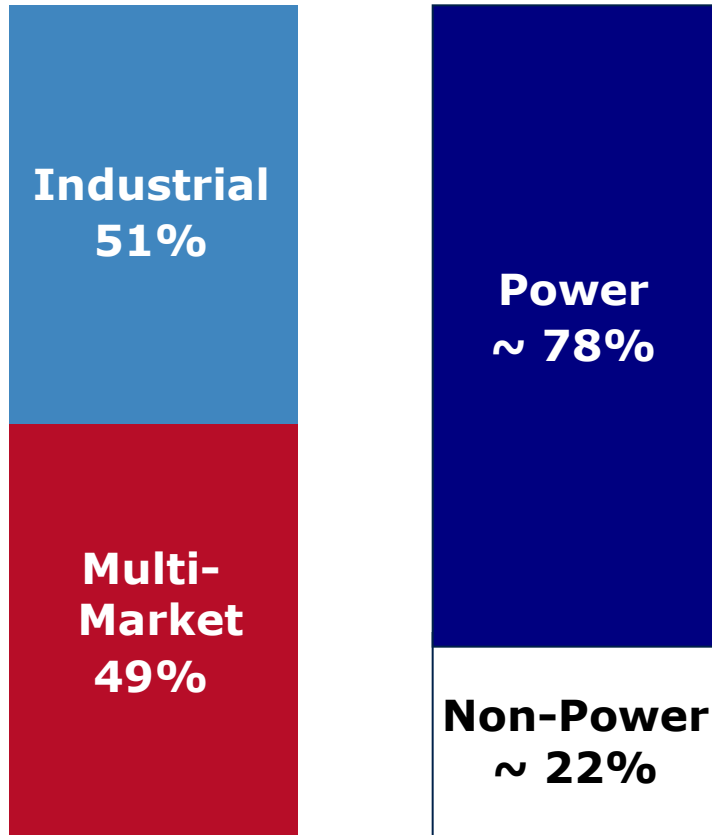

**IMM**

## IMM product range

- Power modules
- Power discretes
- Power management ICs
- AF/RF diodes, AF/RF transistors, silicon microphone
- ASIC design solutions incl. secure ASICs for authentication and brand protection

# Balanced Application Portfolio; More Than Half of IMM Sales in APAC



## IMM revenue split by application

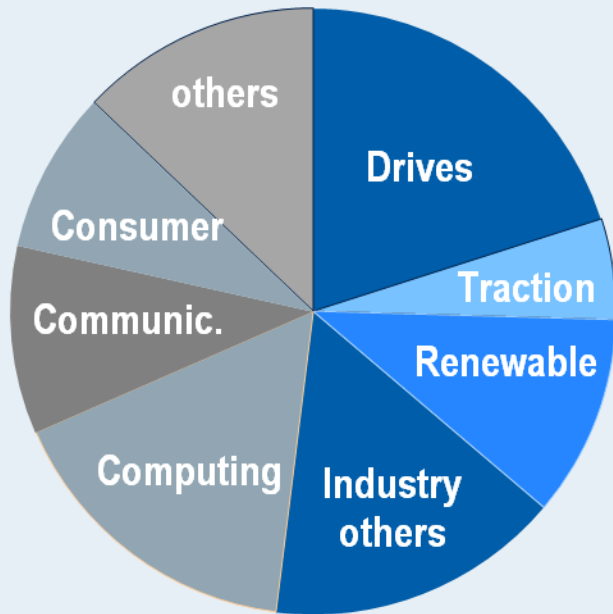

Industrial ~51%, Multimarket ~49%

## IMM revenue split by region

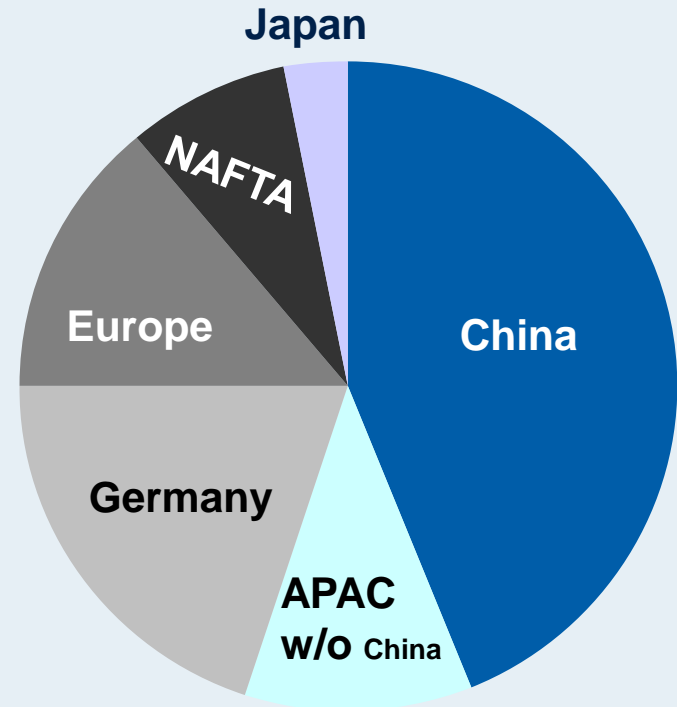

APAC ~55%

# IFX Continues to Gain Market Share in Both Power Discretets and Power Modules Market



## Infineon market share Power Discretets

Market Size in 2009: USD 8.7bn

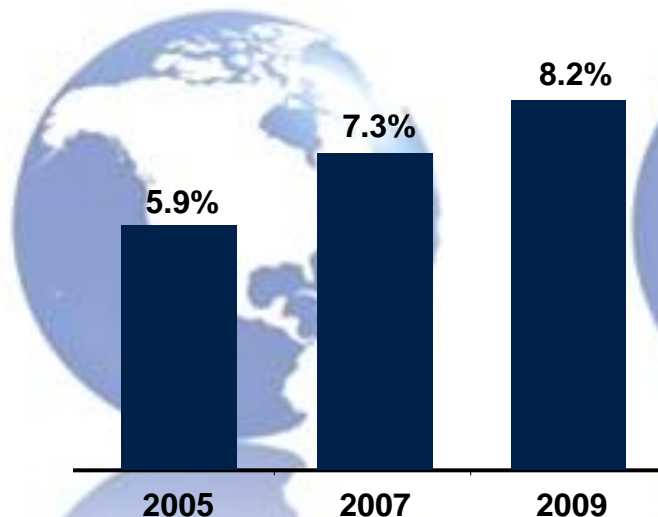

Ranking CY 2009	
<b>1. Infineon</b>	<b>8.2%</b>
=1. Toshiba	8.2%
3. STM	7.8%
4. Fairchild	7.6%
5. Vishay	7.3%

**#1**

Market share  
**11%**

## Infineon market share Power Modules

Market Size in 2009: USD 2.3bn



Ranking CY 2009	
1. Mitsubishi	29.6%
<b>2. Infineon</b>	<b>20.5%</b>
3. Semikron	13.3%
4. Fuji Electric	8.4%
5. Hitachi	3.7%

Source: IMS Research, Global Market for Power Semiconductor Discretets & Modules, August 2010.

# Demand for Energy Continues to Grow – ~1/3 of Energy Consumption is Electricity

## World energy consumption, 1970 – 2035

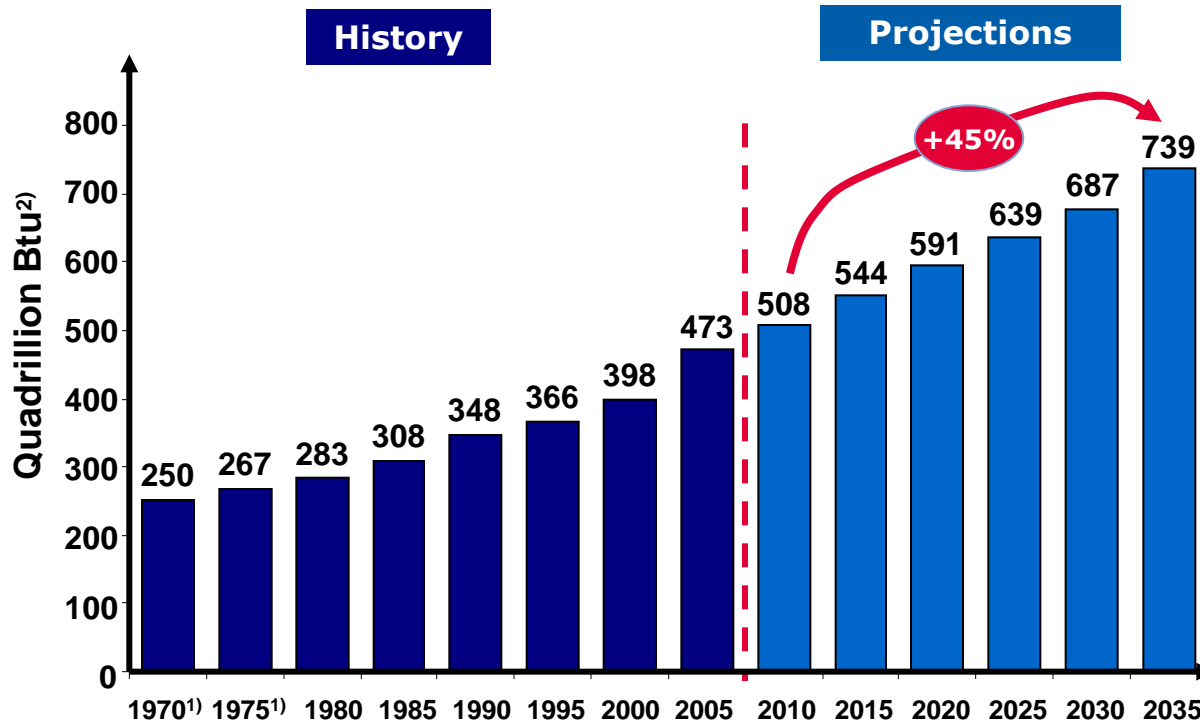

## World Energy Consumption 2007

Approximately one third of global energy use is based on electricity.

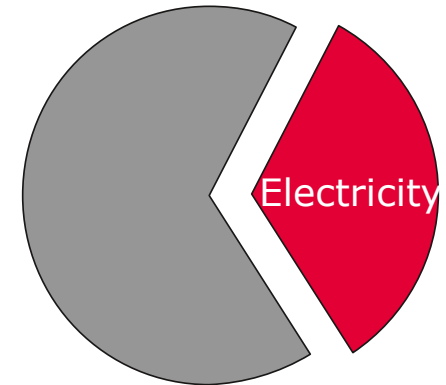

Sources: Energy Information Administration (EIA), International Energy Outlook 2009, 2010, BP World Energy report  
 1) Infineon estimates based on IEA 2006  
 2) British thermal unit (Btu): 1 Btu = 1,05506 kJ

# Power Semiconductors Play a Major Role in the Whole Electrical Energy Supply Chain



Energy supply chain

## Energy generation



## Energy distribution

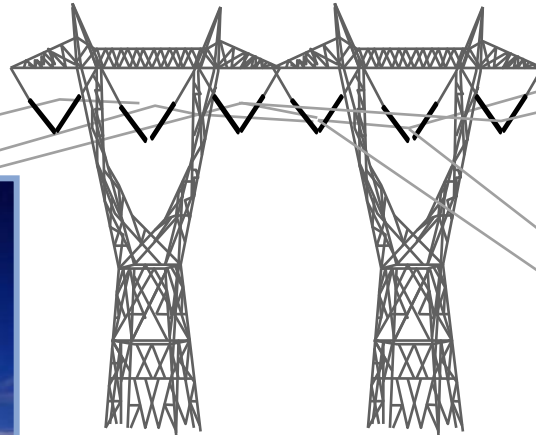

## Energy consumption



Power SC & Modules



**Stacks**



**Power Modules**



**Thyristors**



**CoolMOS™**



**TRENCHSTOP™  
SiC (thinQ!™)**



**OptiMOS™  
PRIMAION**

# Continuous Growth in Wind and Solar; First Design-Wins in Chinese Wind Market



## Solar power

- Solar installations typically range from ~5 kW (on-roof PV) to ~50 MW (solar farm).
- Power semiconductor content in solar installations accounts for ~ EUR 25 to EUR 350,000.
- Products: CoolMOS™, SiC diodes, discrete IGBTs and IGBT modules.

## Wind power

- Wind mills typically range from ~2 MW (on-shore) to ~5 MW (off-shore).
- Power semiconductor content in wind mills accounts for ~ EUR 6k to EUR 25k.
- Products: IGBT modules, thyristor discs and modules and complete inverter stacks.

### Converter



### EconoDUAL™3



### Shenzhen Hopewind

- First design-wins in China at Shenzhen Hopewind Electric Co., Ltd., a leading Chinese wind energy converter manufacturer.
- Infineon parts: EconoDUAL™3



# Motor Drives and Traction Are Propelled by Environmental Awareness and Urbanization

## Energy efficient motor drives

## Infrastructure

## Transportation

### Steel



### Water/Wastewater



### Train



### Cement



### Logistics



### Metro



### Pulp/Paper

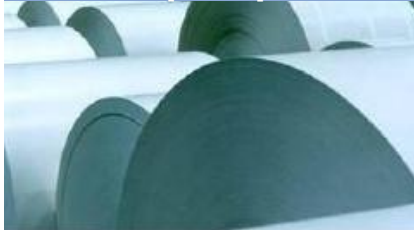

### Buildings



### CAV



- Drives and traction applications typically range from few kW to 100 MW.
- Power semiconductor content accounts for ~ EUR 5 (small drives) to EUR 100k in a high speed train.
- Products: power discretes, power modules and stacks, driver ICs.

Sources: Infineon AG, Siemens AG

CAV: Commercial, Agriculture and Construction Vehicles

# China Railways Has Seen Strong Stimulus Support; Network Build-out Continues

## The renaissance of trains: High-speed and urban electric trains

**China's Ministry of Railways** is planning to expand the operating length of the Rail network from 86,000 km in 2009 to 120,000 km by 2020. The corresponding fixed asset investment required is USD 450bn, of which USD 125bn has been spent already.

- **Very high-speed rail network:** The Ministry of Railways expects to increase the high speed rail operating length from 13,000 km today to 20,000 km by 2020, implying 54% growth overall.
- **Urban/Mass transit markets:** To support the plans to urbanize 300m people by 2030, the government wants to build out the transport network in metros. This is the fastest growing segment with the operating length growing nearly 6.5x, from 960 km in 2009 to 11,700 km by 2020.

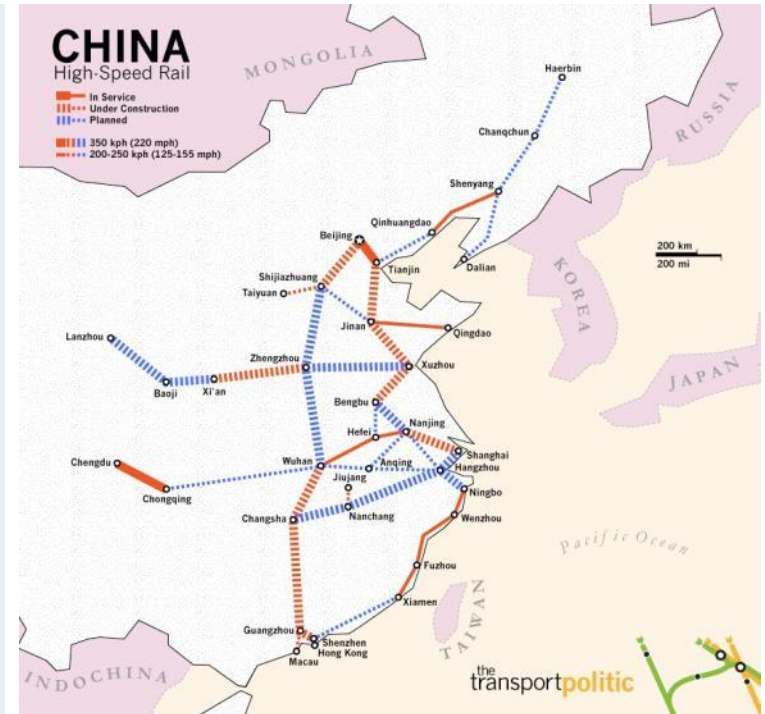



# Siemens Velaro Selected by EuroStar; EUR 50k to 100k Semi Content Per Train



- 10 trains ordered for EUR 600m in total.
- 130 IGBT modules per train resulting in EUR 50k to 100k power semiconductor content per train.
- Power semiconductors represent only 0.15 to 0.2% of system cost but contribute significantly to the entire functionality.



# Highest Efficiency in Power Architecture is Key for Today's Computing Applications



- Worldwide approx. 145 mio<sup>(1)</sup> new desktop PCs are sold per year.
- 300 W silverbox running at average load of 50%.
- For 8 h per day electrical energy consumption would be **63,500 GWh per year.**
- 1% efficiency increase  $\cong$  saving of **635 GWh per year**  $\cong$  **net savings of  $\sim$ 320,000 tons CO<sub>2</sub>/year<sup>(2)</sup>.**

⇒ **2009: advanced Infineon power technologies like CoolMOS™ and SiC enabled reduction of CO<sub>2</sub> emissions of approx. 140,000 tons!**

- Computing applications typically range from 50 W to  $\sim$ 3 kW.
- Power semiconductor content in computing applications range from EUR 1 to EUR 50.
- Products: CoolMOS™, OptiMOS™, SiC products, driver ICs and digital power controllers (Primarion™).



<sup>(1)</sup> Infineon estimate based on external analyst figures (Gartner; JPMorgan, 2010).

<sup>(2)</sup> Assuming 500 g CO<sub>2</sub>/kWh (average based on values from literature ranging from 375 g CO<sub>2</sub>/kWh (EU-commission) to 750 g CO<sub>2</sub>/kWh (Solar World)).

# Table of Contents

■ Infineon Results and Outlook

■ Business Highlights

■ Infineon's Superior Manufacturing Technologies

# Unique Manufacturing Know-How in Ultra-thin Wafers

## IGBT transistor

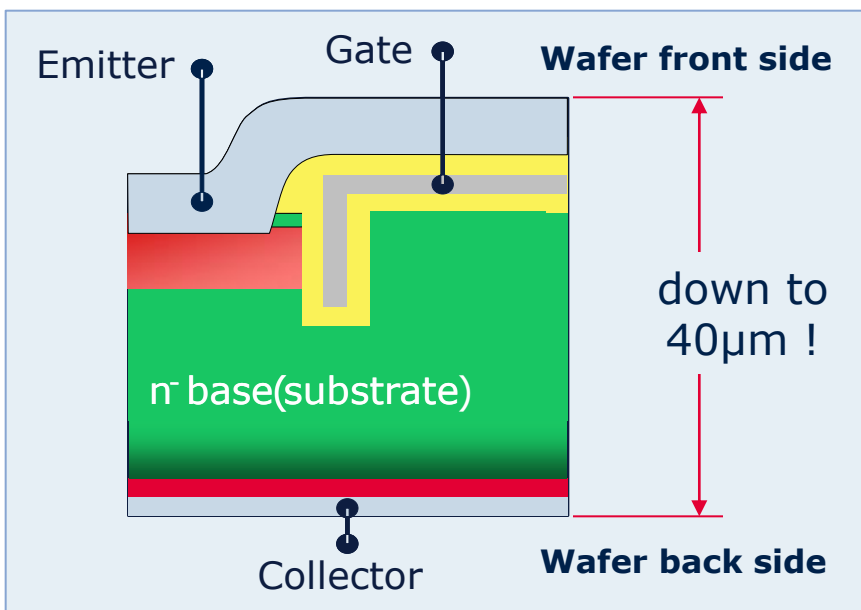

## Applications

- Speed-controlled motors for traction, drives, pumps, and fans
- Power supplies
- Lighting
- Inductive cooking
- Automotive

## Manufacturing competencies

- Ultra-thin wafer handling
- Frontside processing
- Backside processing
- Outstanding cost performance, e.g. IGBTs and SiC diodes



$Rev_{cum}^* = \sim EUR 136m$

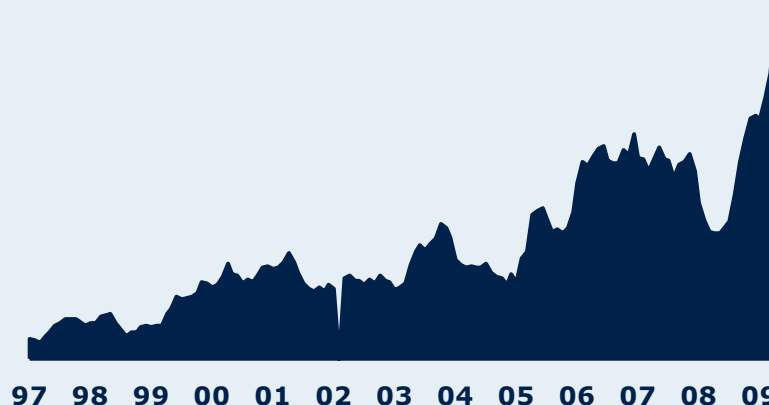

\* = Cumulated revenue of all thin wafer IGBTs over lifetime.

# Unique Technology and Manufacturing Know-How in Silicon-Carbide (SiC)

## Silicon-carbide diode

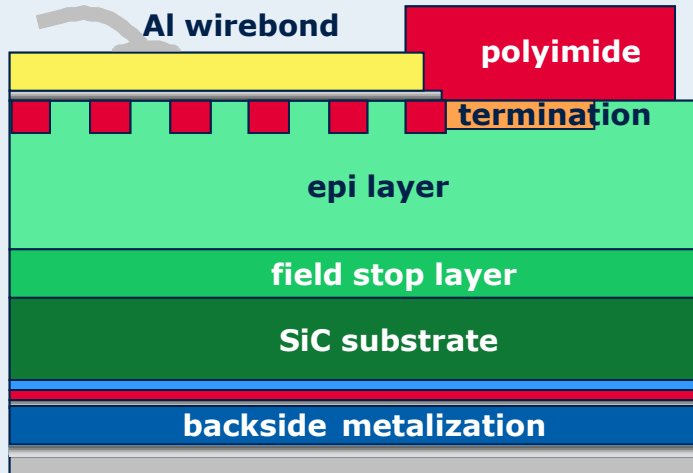

## Manufacturing competencies

- 100 mm SiC manufacturing line in Villach, Austria, on standard 150/200mm equipment.
- World's 1<sup>st</sup> 10x100 mm SiC epi system.
- About 30-50% smaller chip size than competition with same performance.
- Special high-temperature processes.

$$\text{Rev}_{\text{cum}}^* = \sim \text{EUR } 12\text{m}$$

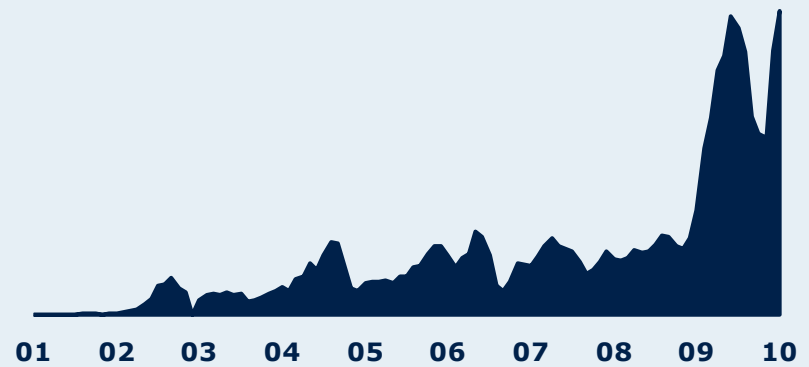

\* = Cumulated revenue of all SiC products over lifetime.

## Applications

- Power factor correction in high-end power supplies (server, telecom, flat panel displays).
- Solar inverter.
- Speed-controlled motors for traction and drives.

# Outstanding Electrical Performance With CoolMOS™ Super-Junction Power MOSFETs

## Super-junction transistor

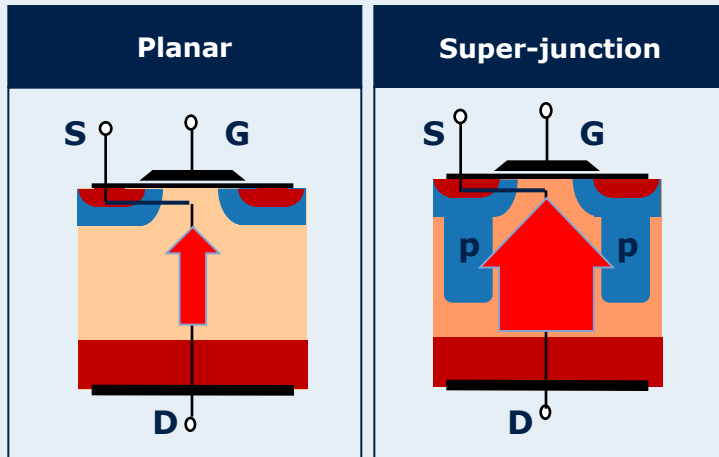

## Manufacturing competencies

- In the late 1990s, a super-junction transistor was invented, dubbed CoolMOS™.
- Manufacturing improvements led to a cost reduction by a factor of 4.
- Reduction of RDS(on) by a factor of 6.

## Applications

- Power supplies for servers, PCs, notebooks, games consoles, adapters.
- Graphics boards
- Lighting
- Solar inverter
- Automotive

$Rev^*_{cum} = \sim EUR 1.4bn$

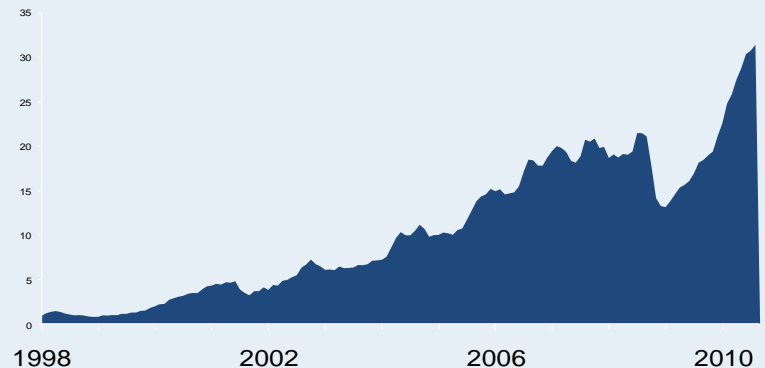

\* = Cum. revenue of all CoolMOS™ products over lifetime.

# .XT Technology Will Improve Lifetime By a Factor of 10 Versus Standard Technology

- Emerging applications requiring longer life time.
- Trend to higher power density leads to new internal packaging technology.
- .XT technology is a set of internal connection technologies that will improve all life time limiting areas within an IGBT module.
- Start of Production: 2011.

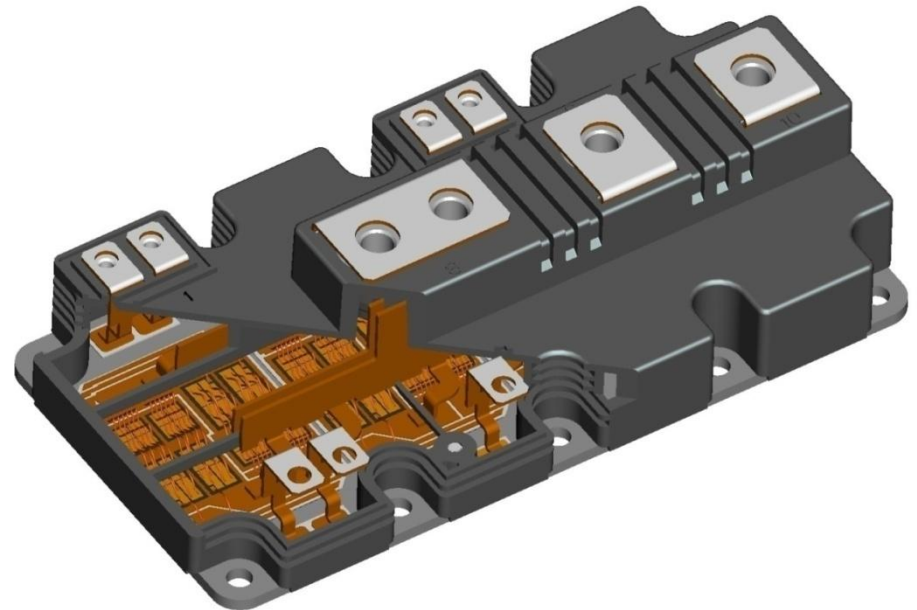

# What Is .XT Technology?

## Standard technology

Chip-to-substrate joint

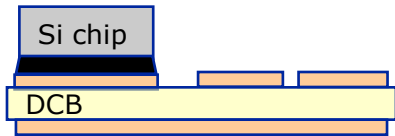

Soft soldering with SnAg paste

Front side interconnect

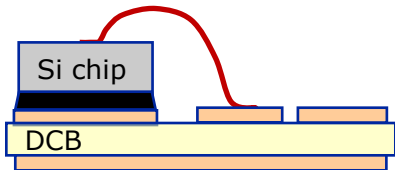

Al wedge bonding

Substrate-to-base plate joint

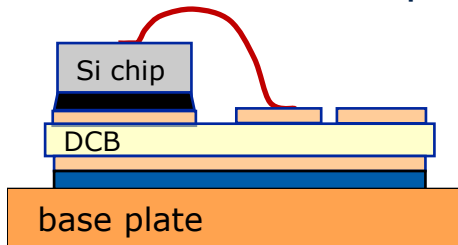

Soft soldering with SnAg pre-form



Diffusion soldering

Cu wedge bonding

High reliability system soldering





# ENERGY EFFICIENCY MOBILITY SECURITY

Innovative semiconductor solutions for energy efficiency, mobility and security.



# Notes

Investments =

- 'Purchase of property, plant and equipment'
- + 'Purchase of intangible assets, and other assets' incl. *capitalization of R&D expenses*

Working Capital =

- ('Total current assets'
- 'Cash and cash equivalents'
- 'Available-for-sale financial assets'
- 'Assets classified as held for disposal')
- ('Total current liabilities'
- 'Short term debt and current maturities of long-term debt'
- 'Liabilities classified as held for sale')

Net Inventory Reach (days of inventory; quarter-to-date) =

$$('Net\ Inventories' / 'Cost\ of\ goods\ sold') * 90$$

DSO (days of sales outstanding; quarter-to-date) =

$$('Trade\ accounts\ receivables\ (net)' / 'Revenue') * 90$$

DPO (days of payables outstanding; quarter-to-date) =

$$('Trade\ accounts\ payables' / ['Cost\ of\ goods\ sold' + 'Purchase\ of\ property,\ plant\ and\ equipment']) * 90$$

# Infineon Consolidated Statements of Operations (IFRS) (unaudited)



in Euro million	3 months ended			12 months ended	
	Sep 30, 10	Jun 30, 10 <sup>(1)</sup>	Sep 30, 09 <sup>(1)</sup>	Sep 30, 10	Sep 30, 09 <sup>(1)</sup>
Revenue	942	885	609	3,295	2,184
Cost of goods sold	(563)	(553)	(427)	(2,058)	(1,687)
<b>Gross profit</b>	<b>379</b>	<b>332</b>	<b>182</b>	<b>1,237</b>	<b>497</b>
Research and development expenses	(114)	(100)	(78)	(399)	(319)
Selling, general and administrative expenses	(103)	(100)	(77)	(386)	(332)
Other operating income	7	2	5	18	17
Other operating expense	(15)	(15)	13	(122)	(46)
<b>Operating income (loss)</b>	<b>154</b>	<b>119</b>	<b>45</b>	<b>348</b>	<b>(183)</b>
Financial income	5	5	1	29	101
Financial expense	(16)	(12)	(37)	(95)	(154)
Income from investments accounted for using the equity method	1	4	2	8	7
<b>Income (loss) from continuing operations before income taxes</b>	<b>144</b>	<b>116</b>	<b>11</b>	<b>290</b>	<b>(229)</b>
Income tax benefit (expense)	49	(13)	(1)	22	(4)
<b>Income (loss) from continuing operations</b>	<b>193</b>	<b>103</b>	<b>10</b>	<b>312</b>	<b>(233)</b>
Income (loss) from discontinued operations, net of income taxes	197	23	1	348	(441)
<b>Net income (loss)</b>	<b>390</b>	<b>126</b>	<b>11</b>	<b>660</b>	<b>(674)</b>
Non-controlling interests	-	-	-	1	(48)
Shareholders of Infineon Technologies AG	390	126	11	659	(626)

## Basic and diluted earnings (loss) per share attributable to shareholders of Infineon Technologies AG (in Euro):

Weighted average shares outstanding (in million) – basic	1,087	1,087	977	1,087	855
Weighted average shares outstanding – diluted	1,172	1,172	977	1,171	855

Basic earnings (loss) per share from continuing operations	0.18	0.10	0.01	0.29	(0.27)
Basic earnings (loss) per share from discontinued operations	0.18	0.02	-	0.32	(0.46)
<b>Basic earnings (loss) per share</b>	<b>0.36</b>	<b>0.12</b>	<b>0.01</b>	<b>0.61</b>	<b>(0.73)</b>

Diluted earnings (loss) per share from continuing operations	0.16	0.09	0.01	0.28	(0.27)
Diluted earnings (loss) per share from discontinued operations	0.17	0.02	-	0.30	(0.46)
<b>Diluted earnings (loss) per share</b>	<b>0.33</b>	<b>0.11</b>	<b>0.01</b>	<b>0.58</b>	<b>(0.73)</b>

<sup>(1)</sup> Prior period figures have been adjusted.

# Infineon Consolidated Statements of Financial Position (IFRS) (unaudited)



in Euro million	Sep 30, 10	Jun 30, 10 <sup>(1)</sup>	Sep 30, 09 <sup>(1)</sup>
<b>Assets</b>			
Current assets:			
Cash and cash equivalents	1,667	1,452	1,414
Available-for-sale financial assets	60	62	93
Trade and other receivables	687	685	514
therein: Trade accounts receivables	622	591	449
Inventories	514	551	460
Income tax receivable	7	19	11
Other current financial assets	72	9	26
Other current assets	88	145	114
Assets classified as held for sale	495	24	112
<b>Total current assets</b>	<b>3,590</b>	<b>2,947</b>	<b>2,744</b>
Property, plant and equipment	838	808	928
Goodwill and other intangible assets	87	384	369
Investments accounted for using the equity method	35	39	27
Deferred tax assets	308	175	156
Other financial assets	119	135	124
Other assets	16	30	18
<b>Total assets</b>	<b>4,993</b>	<b>4,518</b>	<b>4,366</b>
<b>Liabilities and equity</b>			
Current liabilities:			
Short-term debt and current maturities of long-term debt	133	127	521
Trade and other payables	665	577	393
therein: Trade accounts payables	659	572	384
Current provisions	553	483	436
Income tax payable	111	119	102
Other current financial liabilities	16	54	50
Other current liabilities	153	247	147
Liabilities classified as held for sale	177	14	9
<b>Total current liabilities</b>	<b>1,808</b>	<b>1,621</b>	<b>1,658</b>
Long-term debt	263	279	329
Pension plans and similar commitments	146	103	94
Deferred tax liabilities	11	8	13
Long-term provisions	55	59	89
Other financial liabilities	6	4	5
Other liabilities	79	134	85
<b>Total liabilities</b>	<b>2,368</b>	<b>2,208</b>	<b>2,273</b>
<b>Shareholders' equity:</b>			
Ordinary share capital	2,173	2,173	2,173
Additional paid-in capital	6,048	6,048	6,048
Accumulated deficit	(5,613)	(5,911)	(6,180)
Other reserves	17	-	(8)
<b>Total equity attributable to shareholders of Infineon Technologies AG</b>	<b>2,625</b>	<b>2,310</b>	<b>2,033</b>
<b>Non-controlling interests</b>	<b>-</b>	<b>-</b>	<b>60</b>
<b>Total equity</b>	<b>2,625</b>	<b>2,310</b>	<b>2,093</b>
<b>Total liabilities and equity</b>	<b>4,993</b>	<b>4,518</b>	<b>4,366</b>

<sup>(1)</sup> Prior period figures have been adjusted.

# Infineon Consolidated Statements of Cash Flows (IFRS) (unaudited)



in Euro million	3 months ended		
	Sep 30, 10	Jun 30, 10	Sep 30, 09
Net income (loss)	390	126	11
Less: net loss (income) from discontinued operations	(197)	(23)	(1)
Adjustments to reconcile net income (loss) to cash provided by (used in) operating			
Depreciation and amortization	85	80	98
Provision for (recovery of) doubtful accounts	-	1	-
Losses on sales of available-for-sale financial assets	-	-	2
Losses in connection with the deconsolidation of ALTIS	(14)	(4)	-
Losses (gains) on disposals of property, plant, and equipment, and other assets	-	(1)	1
Income from investments accounted for using the equity method	(1)	(4)	(3)
Dividends received from associated companies	4	3	-
Impairment charges	-	5	3
Share-based compensation	-	-	1
Deferred income taxes	(55)	(7)	(2)
Changes in operating assets and liabilities:			
Trade and other receivables	6	(82)	(17)
Inventories	(8)	(18)	31
Other current assets	34	(7)	(4)
Trade and other payables	92	83	12
Provisions	114	(46)	(2)
Other current liabilities	(70)	174	28
Other assets and liabilities	25	(2)	5
Interest received	3	5	5
Interest paid	(1)	(25)	(4)
Income tax received (paid)	(8)	(8)	1
Net cash provided by (used in) operating activities from continuing operations	399	250	165
Net cash provided by (used in) operating activities from discontinued operations	(12)	(11)	24
Net cash provided by (used in) operating activities	387	239	189
Cash flows from investing activities:			
Proceeds from sales of available-for-sale financial assets	2	375	6
Proceeds from sales of businesses and interests in subsidiaries	1	-	-
Purchases of intangible assets, and other assets	(8)	(9)	(5)
Purchases of property, plant and equipment	(155)	(71)	(21)
Proceeds from sales of property, plant and equipment, and other assets	(1)	3	1
Net cash provided by (used in) investing activities from continuing operations	(161)	298	(19)
Net cash provided by (used in) investing activities from discontinued operations	(8)	(35)	(18)
Net cash provided by (used in) investing activities	(169)	263	(37)
Cash flows from financing activities:			
Net change in short-term debt	-	(8)	-
Net change in related party financial receivables and payables	2	-	-
Proceeds from issuance of long-term debt	2	2	-
Principal repayments of long-term debt	(13)	(267)	(188)
Change in restricted cash	1	(1)	-
Proceeds from issuance of ordinary shares	-	-	680
Dividend payments to minority interests	-	-	3
Net cash provided by (used in) financing activities from continuing operations	(8)	(274)	495
Net cash provided by (used in) financing activities from discontinued operations	-	-	-
Net cash provided by (used in) financing activities	(8)	(274)	495
Net increase (decrease) in cash and cash equivalents	210	228	647
Effect of foreign exchange rate changes on cash and cash equivalents	5	(4)	-
Cash and cash equivalents at beginning of period	1,452	1,228	767
Cash and cash equivalents at end of period	1,667	1,452	1,414

# Financial Calendar and IR Contacts

## Financial Calendar

- Feb 17, 2011  
**Annual Shareholder Meeting**
- Feb 01, 2011\*  
**Q1 FY11 Results**
- May 03, 2011\*  
**Q2 FY11 Results**
- Jul 28, 2011\*  
**Q3 FY11 Results**
- Nov 17, 2011\*  
**Q4 FY11 Results**

\* Preliminary Date

## IR Contacts

### Ulrich Pelzer

Corporate Vice President  
Corporate Development & Investor Relations

☎ +49 89 234-26153

✉ [ulrich.pelzer@infineon.com](mailto:ulrich.pelzer@infineon.com)

### Joachim Binder

Senior Director, Investor Relations

☎ +49 89 234-25649

✉ [joachim.binder@infineon.com](mailto:joachim.binder@infineon.com)

### Aleksandar Josic

Manager, Investor Relations

☎ +49 89 234-83045

✉ [aleksandar.josic@infineon.com](mailto:aleksandar.josic@infineon.com)

# Disclaimer

This presentation was prepared as of November 16, 2010 and is current only as of that date.

This presentation includes forward-looking statements and assumptions about the future of Infineon's business and the industry in which we operate. These include statements and assumptions relating to general economic conditions, future developments in the world semiconductor market, our ability to manage our costs and to achieve our growth targets, the resolution of Qimonda's insolvency proceedings and the liabilities we may face as a result of Qimonda's insolvency, the successful closing of the sale of our WLS business to Intel, the benefits of research and development alliances and activities, our planned levels of future investment, the introduction of new technology at our facilities, our continuing ability to offer commercially viable products, and our expected or projected future results.

These forward-looking statements are subject to a number of uncertainties, such as broader economic developments, including the sustainability of recent improvements in the market environment; trends in demand and prices for semiconductors generally and for our products in particular, as well as for the end-products, such as automobiles and consumer electronics, that incorporate our products; the success of our development efforts, both alone and with partners; the success of our efforts to introduce new production processes at our facilities; the actions of competitors; the continued availability of adequate funds; any mergers, acquisitions or dispositions we may undertake; the outcome of antitrust investigations and litigation matters; and the resolution of Qimonda's insolvency proceedings; as well as the other factors mentioned in this presentation and those described in the "Risk Factors" section of our most recent annual report on Form 20-F on file with the U.S. Securities and Exchange Commission.

As a result, Infineon's actual results could differ materially from those contained in or suggested by these forward-looking statements. You are cautioned not to place undue reliance on these forward-looking statements. Infineon does not undertake any obligation to publicly update or revise any forward-looking statements in light of developments which differ from those anticipated.